



Models:
 ▶ **CBS-2131**
 ▶ **CBS-2132**
 3 liter and 1 gallon airpot brewers



CBS-2131 - Single 3 Liter Airpot Coffee Brewer



CBS-2132 - Twin 1 Gallon Airpot Coffee Brewer



NOTICE TO INSTALLER: Please leave this book with the machine.

Table of Contents

Contact Information	2	Operating Instructions.....	10
Description & Features	2	Programming- operator access programming	12
Specifications.....	2	Hot water convenience tap	17
Requirements	2	Adjustable spray pattern	17
Weights Capacities and Measurements	3	Error Codes.....	17
Electrical Configuration and Brewing Efficiency	3	Airpot use instructions and cleaning.....	18
Installation.....	5	Parts diagrams, bill of materials lists	22
Accessing batch and programming menu screens	8	Wiring diagrams	33

FETCO®, LUXUS®, EXTRACTOR®, INTERMITTENT BREW, and Driven To Innovation™ are trademarks or trade names of Food Equipment Technologies Company.

Contact Information

FETCO®
Food Equipment Technologies Company
600 Rose Road
Lake Zurich • IL • 60047-0429 • USA

Phone: (800) 338-2699 (US & Canada)
(847) 719-3000
Fax: (847) 719-3001

Email: sales@fetco.com
techsupport@fetco.com

Internet: www.fetco.com

Description & Features

The CBS-2130 Series coffee brewers feature our universal spray over technology, which works like this:

The following variables are programmed for each batch size:

- ❖ Brew volume
- ❖ Brew time
- ❖ Adjustable number of pulses
- ❖ Three selectable spray patterns
- ❖ Prewet percent (Percentage of the brew volume)
- ❖ Prewet delay (The time between prewetting and the brew cycle.)
- ❖ Bypass percent (Percentage of the brew volume)
- ❖ Drip delay (The time between the end of the brew cycle to empty the brewbasket and end of the brewing cycle.)

Using these variables, the software calculates how much water to use for prewetting, bypass (optional), and brewing. The total brew time is divided into several cycles. Within these cycles, the software calculates how long to spray water over the coffee grounds, and how long to pause before the next cycle begins. The optional bypass valve opens at the beginning of the brew cycle and dispenses the correct amount of water all at once. Spray pattern into brew basket may be user set for perfect penetration.

Features

- ❖ Touchscreen Operation
 - ❖ Cascading Spray Dome-no holes to clog in sprayhead
 - ❖ Four fully programmable batch sizes per side
 - ❖ Batch sizing
 - ❖ Customizable batch name
 - ❖ Recipe copy
 - ❖ Screen logo customizable by user from SD card
 - ❖ SD card firmware program and upgrade installation
 - ❖ User programs save to and load from SD cards
 - ❖ Pump circuit calibration on startup
 - ❖ Magnetic flux brew basket sensor
 - ❖ Dispenser locator under brew basket
 - ❖ Brew at temperature protection
 - ❖ Brew mechanism is digitally adjustable
 - ❖ Adjustable bypass (with bypass option)
 - ❖ Three adjustable spray patterns
 - ❖ Totalizing counters for brewer functions
 - ❖ Shipped ready to operate out of the box
-

Specifications

Requirements

- ❖ **Water Requirements:**
 - CBS-2131: 20-75 psig (138-517kPa) 1½gpm/(5.7lpm)
 - CBS-2132: 20-75 psig (138-517kPa) 1½gpm/(5.7lpm)
- ❖ **Water inlet fitting** is a 1/4 inch male flare.
- ❖ **Brew Volume:**
 - Full Batch 3 liter CBS-2132 & CBS-2131—3 liter version
 - Full Batch 1gal. CBS-2132 & CBS-2131—1 gal. version
- ❖ **Inlet Water Temperature:** Cold or Hot supply
- ❖ **Coffee Filter Size:** 13"X5"—standard FETCO # F002
- ❖ **Electrical:** See electrical configuration chart.
- ❖ **Temperature:** 200°F (93°C) inside water tank (at sea level)
195°F (91°C) ± 5° at sprayhead

Designs, materials, specifications, physical dimensions, firmware and software protocol for equipment or replacement parts are subject to change by FETCO without notice.

Weights Capacities and Measurements

Weights and Capacities & Measurements; 3 liter and 1 gallon brewers								
Brewer	Height	Width	Depth	Empty Weight	Filled Weight	Total Weight- Brewer & Filled Dispenser	Shipping Weight	Shipping Dimensions
CBS-2131 3 liter	21 3/8" 54.3cm	11 3/4" 30.3cm	20 3/8" 51.8cm	29 lb 13.1kg	50 lb 22.7 kg	61.2lb 27.8 kg	36.3 lb 16.5 kg	22 3/4" x 16 5/8" x 22 7/8" 57.8 x 42.3 x 58.1cm
CBS-2131 1 gallon	23 3/8" 59.4cm	11 3/4" 30.3cm	20 3/8" 51.8cm	29 lb 13.1kg	50 lb 22.7 kg	63lb 28.6 kg	36.3 lb 16.5 kg	22 3/4" x 16 5/8" x 22 7/8" 57.8 x 42.3 x 58.1cm
CBS-2132 3 liter	21 3/8" 54.3cm	19 3/4" 50.2cm	20 3/8" 51.8cm	42.6lb 19.3 kg	87.6 lb 39.7kg	110lb 49.9 kg	49.4 lb 22.4 kg	24 1/2" x 22 7/8" x 23" 62.2 x 58.1 x 58.4cm
CBS-2132 1 gallon	23 3/8" 59.4cm	19 3/4" 50.2cm	20 3/8" 51.8cm	42.6lb 19.3 kg	87.6 lb 39.7 kg	114 lb 51.7 kg	49.4 lb 22.4 kg	24 1/2" x 22 7/8" x 23" 62.2 x 58.1 x 58.4cm

Electrical Configuration and Brewing Efficiency

Electrical Configurations- CBS-2131—3 liter version									
Configuration Code	Heater Configuration	Bypass	Voltage	Phase	Wires	Electrical Connection	KW	Maximum Amp Draw	Gallon/Hour (3 liters per batch)
E213103	1 X 1.5 kW	NO	100 - 120	1	2+G	NEMA 5-15P	1.1 – 1.6	10.9 – 13.0	3.9 gal/14.8 lit
E213104	1 X 1.7 kW	NO	100 - 120	1	2+G	NEMA 5-15P	1.3 – 1.8	12.3 - 14.7	4.4 gal/16.7 lit
E213101	1 X 2.3 kW	NO	100 - 120	1	2+G	NEMA 5-20P	1.7 – 2.4	16.5 - 19.7	5.8 gal/22 lit
E213105	1 X 2.3 kW	NO	200 - 240	1	2+G	Cord/No Plug	1.7 – 2.4	8.5 – 10.1	5.8 gal/22 lit
E213107	1 X 3.0 kW	NO	200 - 240	1	2+G	Cord/No Plug	2.2 – 3.1	10.9 – 13.0	7.7 gal/29.1 lit

Electrical Configurations- CBS-2132—3 liter version									
Configuration Code	Heater Configuration	Bypass	Voltage	Phase	Wires	Electrical Connection	KW	Maximum Amp Draw	Gallon/Hour (3 liters per batch)
E213201	2 X 2.3 kW	NO	200-240	1	2+G	Terminal Block	3.3 – 4.7	16.5 - 19.7	11.5 gal/43.5 lit
E213202	2 X 3.0 kW	NO	200-240	1	2+G	Terminal Block	4.2 – 6.1	21.3—25.5	14.0 gal/53 lit

Electrical Configurations- CBS-2131—1 gallon airport version									
Configuration Code	Heater Configuration	Bypass	Voltage	Phase	Wires	Electrical Connection	KW	Maximum Amp Draw	Gallon/Hour (1 gallon per batch)
E213102	1 X 2.3 kW	NO	100 - 120	1	2+G	NEMA 5-20P	1.7 – 2.4	16.5 - 19.7	5.8 gal/22 lit
E213112	1 X 2.3 kW	YES	100 - 120	1	2+G	NEMA 5-20P	1.7 – 2.4	16.5 - 19.7	5.8 gal/22 lit
E213106	1 X 2.3 kW	NO	200 - 240	1	2+G	Cord/No Plug	1.7 – 2.4	8.5 – 10.1	5.8 gal/22 lit
E213116	1 X 2.3 kW	YES	200 - 240	1	2+G	Cord/No Plug	1.7 – 2.4	8.5 – 10.1	5.8 gal/22 lit
E213108	1 X 3.0 kW	NO	200 - 240	1	2+G	Cord/No Plug	2.2 – 3.1	10.9 – 13.0	7.7 gal/29.1 lit
E213118	1 X 3.0 kW	YES	200 - 240	1	2+G	Cord/No Plug	2.2 – 3.1	10.9 – 13.0	7.7 gal/29.1 lit

Electrical Configurations- CBS-2132—1 gallon airport version									
Configuration Code	Heater Configuration	Bypass	Voltage	Phase	Wires	Electrical Connection	KW	Maximum Amp Draw	Gallon/Hour (1 gallon per batch)
E213203	2 X 3.0 kW	NO	200-240	1	2+G	Terminal Block	4.2 – 6.1	21.3—25.5	14.0 gal/53 lit
E213213	2 X 3.0 kW	YES	200-240	1	2+G	Terminal Block	4.2 – 6.1	21.3—25.5	14.0 gal/53 lit

Designs, materials, specifications, physical dimensions, firmware and software protocol for equipment or replacement parts are subject to review and change by FETCO without notice

Dimensions & Utility Connections—Rough-in drawings

CBS-2131
3 liter

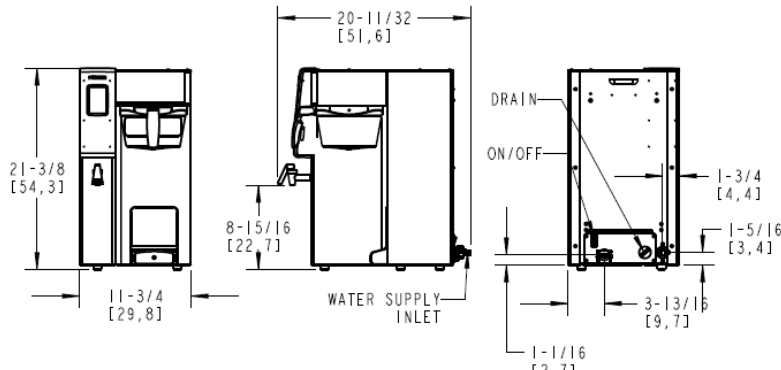

Rough-in CBS-2131—Single station 3 liter airpot version

CBS-2132
3 liter

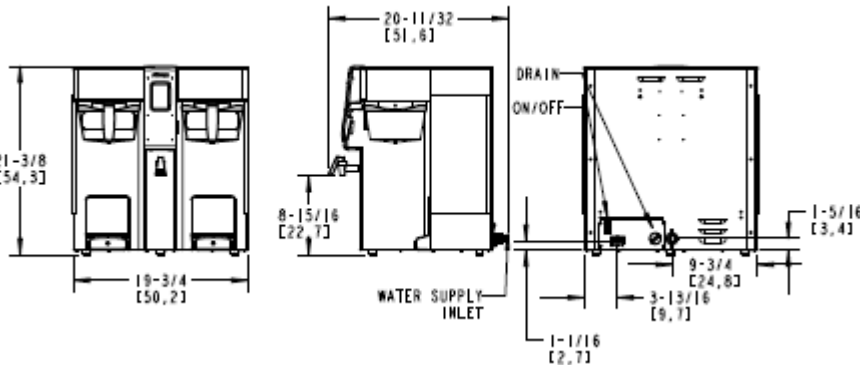

Rough-in CBS-2132—Twin station 3 liter airpot version

CBS-2131
1 gallon

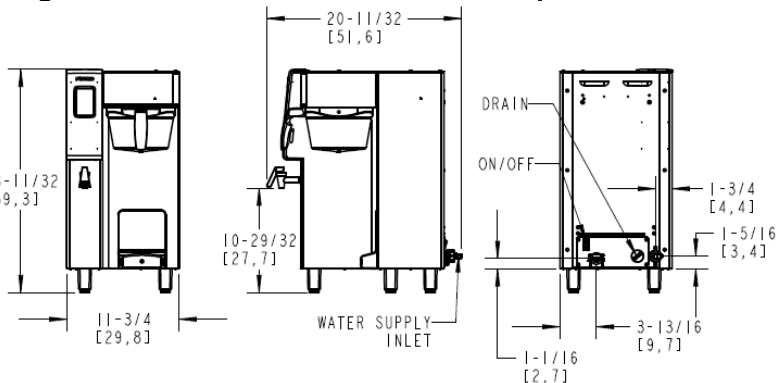

Rough-in CBS-2131—Single station 1 gallon airpot version

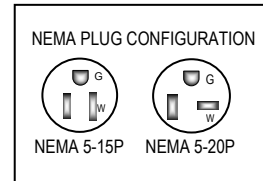

CBS-2132
1 gallon

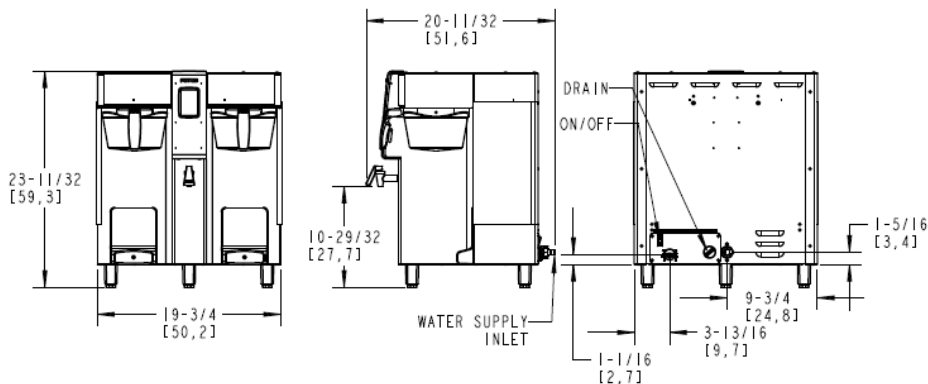

Rough-in CBS-2132—Twin station 1 gallon airpot version

Installation

(For Qualified Service Technicians Only)

Guide to A Successful Installation

If not installed correctly by qualified personnel, the brewer will not operate properly and damage may result. Damages resulting from improper installation are not covered by the warranty, and will void the warranty. Here are the key points to consider before installation:

Electrical:

- ❖ All FETCO brewers require an **electrical ground wire**. Installation without grounding is dangerous.
- ❖ Verify voltages, polarity, circuits, and circuit breaker access before attaching equipment.
- ❖ The electrical diagram is located in the Users Guide and online at www.fetco.com.
- ❖ The installation must comply with applicable federal, state, and local codes having jurisdiction at your location. Check with your local inspectors to determine what codes will apply.

Plumbing:

- ❖ All installations must comply with applicable federal, state, or local plumbing codes.
- ❖ An inline water filter is highly recommended. It should be installed after a water shutoff valve and in a position to facilitate filter replacement.
- ❖ The water line and newly installed filter cartage must be flushed thoroughly prior to connecting it to the brewer to prevent debris from contaminating the machine.
- ❖ Verify that the water line will provide a flow rate of at least 1½gpm/ (5.7lpm) per minute and water pressure is between 20-75 psig (138-517kPa) before making any connections.
- ❖ Install a backflow prevention device if required. Many municipalities require a recognized backflow preventer. Usable on all hot beverage and cold beverage equipment is a WATTS® SD-2 or SD-3. These spring loaded double check valve models are accepted by most zoning authorities. The check valve should be as close to the water supply inlet of the beverage equipment as possible.

General:

- ❖ Utilize only qualified beverage equipment service technicians for installation. A Service Company Directory is available at www.fetco.com.

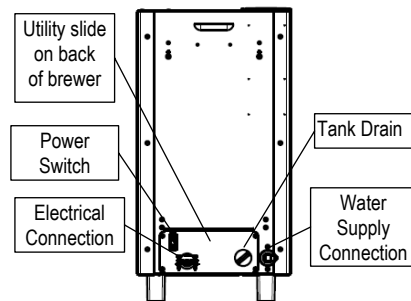
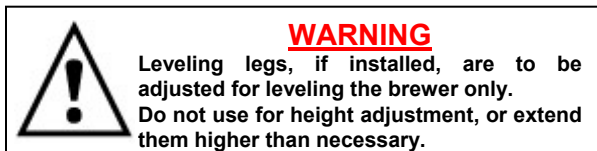

Installation Instructions

Brewer Setup

1. Review the dimensions for the unit and verify that it will fit properly in the space intended for it. Verify that the counter or table will support the total weight of the brewer and dispensers when filled (specifcs-page 3).
2. Place the brewer on the counter or stand.
3. When the brewer is in position, level it front to back as well as side to side by adjusting the legs.
4. For 200-240 volt units: remove the lower utility slide out at the back of the equipment to access the electrical connections. The utility slide must remain close to the unit, Note: it cannot be detached completely.

Water Connection

1. Water inlet is a ¼ inch male flare fitting.
2. The brewer can be connected to a cold or hot water line. Cold water is preferred for best coffee flavor, but hot water will allow for faster recovery times. High temperature water should not exceed 160°F/71°C.
3. Install a water shut off valve near the brewer to facilitate service. An in-line water filter should be used, it should be installed after the water shut off valve and in a position to facilitate filter replacement.
4. Flush the water supply line and filter **before** connecting it to the brewer.
5. Verify that the water line will provide at least 1½gpm/(5.7lpm) per minute for the CBS-2131& CBS-2132 and also that the water pressure is between 20-75 psig (138-517kPa).before connecting it to the brewer.

Electrical Connection – US & Canada

1. Verify that the actual voltage at the electrical service connection is compatible with the specifications on the brewer’s serial number label. Install an electrical ground wire.
2. The temperature and water tank fill level are pre-set at the factory. There is no need to turn off the heaters during the installation process. The heaters are disabled by the control board until the tank is full of water. The heating process will start automatically when the tank has filled.
3. Most CBS-2131 equipment is factory equipped with a 120 V cord and plug. Some CBS-2131 and all CBS-2132 have a terminal block for connecting the incoming power wires. Consult local codes to determine if a cord and plug can be installed on factory supplied terminal block equipment, or if the unit must be hard wired.
4. Plug in unit if the equipment has an attached cord & plug, or, wire into circuit for terminal block units. Note that the plug is NEMA 5-15P or NEMA 5-20P (domestic).
5. A fused disconnect switch or circuit breaker on the incoming power line must be conveniently located near the brewer, and its location and markings known to the operators.
6. The body of the brewer must be grounded to a suitable building ground. A ground lug is provided in the brewer next to the power terminal block. Use 10 gauge copper wire for grounding.
7. Electrical connections must be secured in-place within the unit to meet national and local standards.

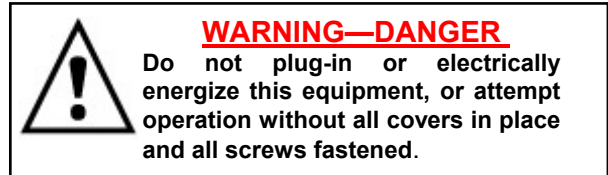
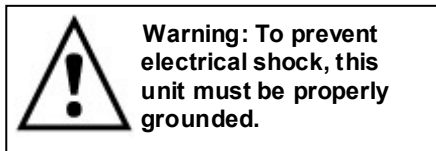

Electrical Configurations Terminal Block Diagram – US & Canada

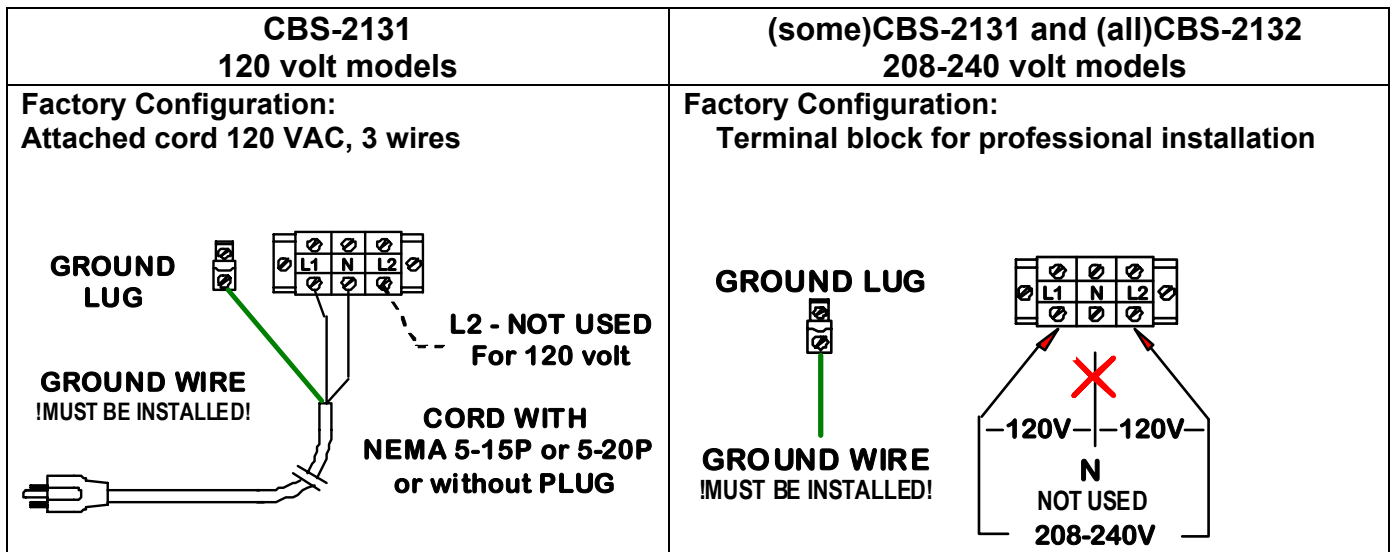

NEW FETCO CONFIGURATIION METHOD!

Final Setup

Final Setup

1. Turn on incoming water supply line and carefully inspect both inside and outside of the brewer for leaks in all fittings and tubes
 2. Turn on power.
 3. Press the brewer's main power switch (located on the lower right of the back of the equipment)
 4. Pre-check will display: "*DC voltage calibration for pumps is running...Please wait...Calibration is successfully done*". (15 seconds)
 5. The water tank will begin filling. FETCO Home Screen #1 will read "FILLING".
 6. When the water level rises and is sensed by the probe at the top of the tank the heaters will activate
 7. Heaters are automatically disabled until the tank is full.
-
8. While the water is heating Screen #2 "HEATING" will display and the actual water temperature will be displayed.
-
9. After the water has reached the set temperature Screen #3 will display "READY"
-
10. Review the Operating Instructions. Brew one full batch (water only) on each side to confirm proper fill levels. The brewer is factory set with water only (no coffee) to dispense the correct amount of water. If the actual volume is slightly different from the programmed volume, fine tuning the brewer may be necessary. See Calibrate Pumps in the OUTPUT section in the PROGRAMMING section.
 11. Re-attach the covers after one final inspection for leaks. Look closely in the top of the brewer section at the dispense fittings during this inspection.

FETCO Home Screen #1 "FILLING"

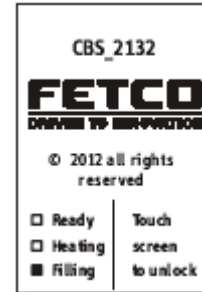

FETCO Home Screen #2 "HEATING"



FETCO Home Screen #3 "READY"



Features of your FETCO Brewer

Touch-screen for brewer operation
 Brew basket sensor (not accessible)
 SD card interface port (Load & Save)
 Hot Water Faucet

Locator removable for service access

Locator for airpot dispenser
 (Two for CBS-2132)

Main power switch

Slide out back panel for service access

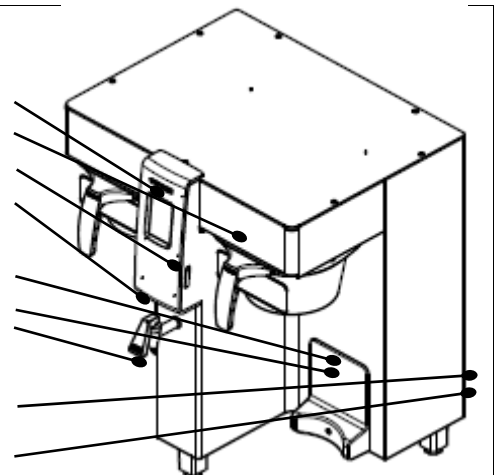

Accessing batch and programming menu screens

Accessing batch and programming menu screens

DC voltage calibration for pumps is running
Please wait...

Calibration is successfully done.

← First message on touchscreen display at powerup. This shows only at "POWER ON", when ON/OFF. The software is analyzing and correcting any variations as a quality control feature.

← FETCO home screen will display on completion

Batch selection and brew operation menu screens



FETCO home screen

← Tap FETCO HOME SCREEN to enter batch selection screen.

Tap left or right side batches→

Hold down batch selector pennant to begin brew.



Operation screens

Programming menu screens

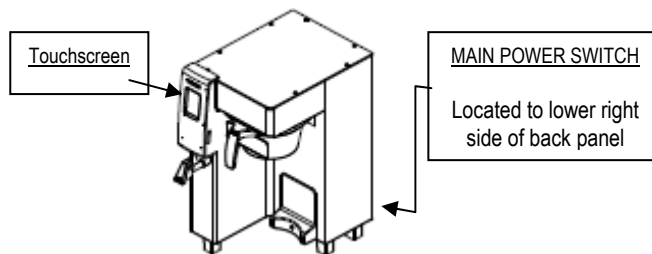

FETCO home screen

DC voltage calibration for pumps is running
Please wait...

Calibration is successfully done.

← First message on touchscreen display at powerup. This shows only at "POWER ON", when ON/OFF. The software is analyzing and correcting any variations as a quality control feature.

← FETCO home screen will display on completion

From power "OFF"→Turn main power switch to "ON"
Touch screen will illuminate, and pump voltage calibration will display
When Complete: FETCO HOME SCREEN will display
Immediately touch and hold finger to enter programming
In 5-8 seconds "PROGRAMMING" screen will appear→



Operator Training

Review the operating procedures with whoever will be using the brewer.

Pay particular attention to the following areas:

1. Always pre-heat the dispensers before the first use of each day by filling them half way with hot water, and letting them stand for at least 5 minutes.
2. Don't remove the brew basket from a coffee brewer until it has stopped dripping.
3. Make sure the dispenser is empty before brewing into it.
4. Show how to attach covers, close, and or secure the dispensers for transporting.
5. Show the location and operation of the water shut off valve as well as the circuit breaker for the brewer.
6. Steam from the tank will form condensation in the vent tubes. This condensation will drip into and then out of the brew baskets. Up to 1/4 cup/118cc discharging overnight is possible. Place an appropriate container under each brew basket when not in use.
7. We recommend leaving the power to the brewer on overnight. The water tank is well insulated and very little electricity is used to keep the tank hot. Leaving the brewer in the "ON" position will also avoid delays at the beginning of shifts for the brewer to reach operating temperature.

Cleaning & Maintenance

After Each Brew:

1. Dispose of grounds and rinse brew basket.
2. Never strike a brewbasket or hit it against a hard surface.
This will damage the brew cone, and may damage the brewbasket support rails
3. Rinse dispensers before reuse.

Every Day:

1. Wash brew basket with hot sudsy water.
2. Pull CSD from the spray head, it is magnetically attached. Use gloves or a heavy towel. → Wash off any film and reattach. Use vinegar if limescale filming is present.
3. Clean dispensers with hot suds water and a brush, rinse and air dry.
4. Use only a soft cloth and hot suds on the outside to avoid scratches. Never use abrasives which will scratch surface.

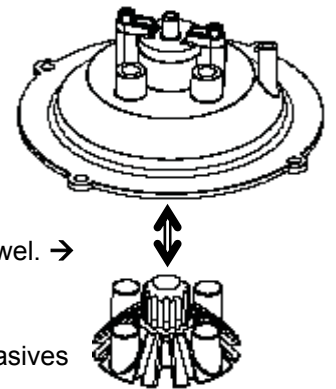

Weekly

1. Use a commercial coffee dispenser cleaner such as URNEX™, TABZ™, DIP-IT™ or Squeak 'n Clean™.
2. Carefully Follow the instructions supplied with the cleaning product
3. Never use spray cleaners, solvent, solvent based cleaner or petroleum based polish anywhere on dispensers

Safety notes

1. Professional installation is required. This appliance is manufactured for commercial use only.
2. Operation requirements and maintenance for commercial cooking appliances differ from household appliances.
3. Operators must be trained for this equipment and must understand the use, maintenance and hazards.
4. Do not attempt to move hot beverage equipment once it is filled. Drain equipment before moving.
5. CBS-2130 series coffee brewers prepare up to 3 liters/1 gallon of coffee or tea in a single batch using very hot water. For safety, the brew basket is locked and may be serviced 5.5 minutes after starting the brew. The factory set brew (default) time is 5.5 minutes with the brew basket locked for safety from start of brew.
! → Never attempt to defeat or override a brew basket locking feature.

Warning

1. Turn off power before any cleaning procedure, including wiping the exterior for appearance reasons.
2. Dry the exterior, especially the face panel, before turning on power.
3. Do not apply any type of spray cleaner on the face panel of this equipment.
4. Never use solvent or solvent-based cleaner or petroleum based polish anywhere on this equipment.
5. Dry the face of the touch pad before turning on power
6. Do not electrically energize this equipment or attempt operation without all covers in place and all screws fastened.
7. Unplug machine before disassembly or servicing.

Operating Instructions

→Quick brewer setup

NOTES

Install plumbing and electrical utilities.	-See Installation Section in this guide
Turn rear power switch "ON".	-Located on back, lower right side
<i>Brewer hot water tank will fill in 4-8 minutes.</i>	-Ready screen will display "•FILLING"
Heater(s) activate when tank is full	-Ready screen will display "•HEATING"
<i>Initial heating will be 15-30 minutes</i>	-Place dispenser under brewbasket(s) to collect any overflow and condensate
<i>Tank displays "• READY" when filled & 200°F/93°C is reached</i>	
Brewer is ready to brew when "• READY" is displayed	-Best results if brewer remains "ON"

Brewing

→To brew a single 3 liter coffee batch, using default recipe

NOTES

FETCO CBS-2130 series equipment is factory calibrated and preloaded with recipes and is ready to brew.	
Place 13"X5" paper filter in brew basket	-FETCO Product # F002 or any 13"X5"
Add 3-8 ounces (85 – 227 g) of ground coffee	-Weights given are only suggested
Insert loaded brewbasket into brewer rails	-Brewbasket(s) must be in place
Have empty dispenser under brewbasket	-Use the convenient locator guide
Tap "• READY" screen to enter the batch selection menu	-A long duration "TAP" with fingertip
Touch a top batch key for "REGULAR 1"	-Touch batch pennant with fingertip
Brewer will brew and display the icon for the function step it is in	-Icon may be toggled for information
On dual side brewer, touch other side to access batches for brewing	-Right to left side switching by touch
Batch will complete brewing in 5 ½ minutes	-Brew time: 4 minutes+1½ min. drip out

Touch the "Ready" screen anywhere briefly to activate



(CBS-2131)

(CBS-2132)

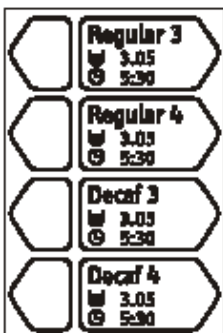





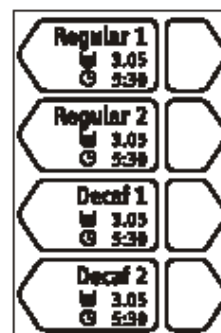

Touch and hold finger on selection pennant for about two seconds to start brew

CBS-2132 selection for brewing on right, left or both sides.

Touch batch pennant to access menu

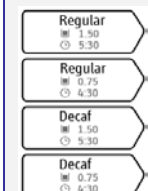
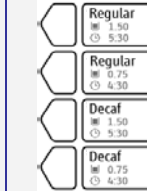

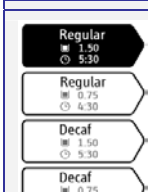
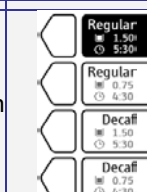
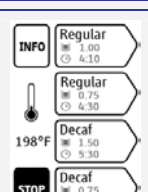
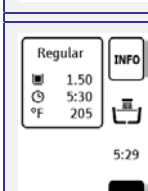
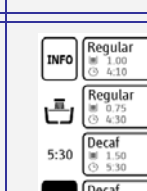
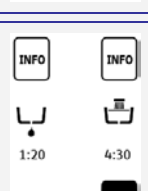
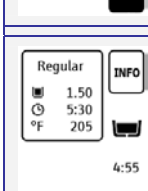
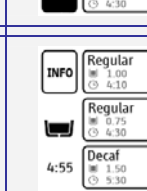
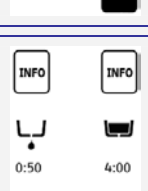
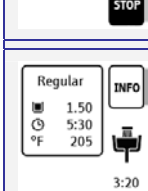
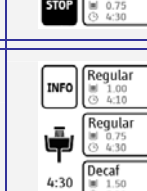
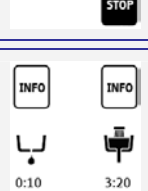
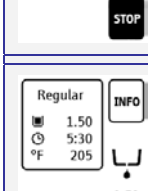
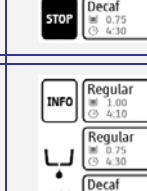
Brewing-shown by touchscreen

Brewer screens displayed for brewing		NOTES	
 <p>CBS_2131 FETCO © 2012 all rights reserved ■ Ready Touch screen to unlock □ Heating □ Filling</p>	<p>“READY SCREEN” Tap screen to display menus</p>	 <p>CBS_2132 FETCO © 2012 all rights reserved ■ Ready Touch screen to unlock □ Heating □ Filling</p>	<p>Note: there are three “BREW AT TEMPERATURE DEFINITONS”. The “Brew at temperature default routine is shown below.</p>
 <p>Regular 1.50 5:30 Regular 0.75 4:30 Decaf 1.50 5:30 Decaf 0.75 4:30</p>	<p>Unit displays four preprogrammed batch buttons per side. CBS-2132 has right and left ←CBS-2131 CBS-2132 →</p>	 <p>Regular 1.50 5:30 Regular 0.75 4:30 Decaf 1.50 5:30 Decaf 0.75 4:30</p>	<p>Brew basket sensor enabled. Unit is brewable only when brebasket is in place. (option may be disabled by user)</p> 
 <p>Regular 1.50 5:30 Regular 0.75 4:30 Decaf 1.50 5:30 Decaf 0.75 4:30</p>	<p>Select and hold one button for 2 seconds</p>	 <p>Regular 1.50 5:30 Regular 0.75 4:30 Decaf 1.50 5:30 Decaf 0.75 4:30</p>	<p>Brew at tempertaure enabled: brew will start when tank temperature reaches he set point</p> 
 <p>Regular 1.50 5:30 205 5:29 STOP</p>	<p>Brew started (in prewet) ←CBS-2131 CBS-2132 →</p>	 <p>Regular 1.00 4:10 Regular 0.75 4:30 Decaf 1.50 5:30 Decaf 0.75 4:30 5:30 STOP</p>	<p>Both sides of CBS-2132 brewing simultanously.</p> 
 <p>Regular 1.50 5:30 205 4:55 STOP</p>	<p>Brewing ←CBS-2131 CBS-2132 →</p>	 <p>Regular 1.00 4:10 Regular 0.75 4:30 Decaf 1.50 5:30 Decaf 0.75 4:30 4:55 STOP</p>	<p>Both sides of CBS-2132 brewing simultanously.</p> 
 <p>Regular 1.50 5:30 205 3:20 STOP</p>	<p>Brewing ←CBS-2131 CBS-2132 →</p>	 <p>Regular 1.00 4:10 Regular 0.75 4:30 Decaf 1.50 5:30 Decaf 0.75 4:30 4:30 STOP</p>	<p>Both sides of CBS-2132 brewing simultanously. Left side completing drip delay</p> 
 <p>Regular 1.50 5:30 205 0:59</p>	<p>Brew completed (in drip delay) ←CBS-2131 CBS-2132 →</p>	 <p>Regular 1.00 4:10 Regular 0.75 4:30 Decaf 1.50 5:30 Decaf 0.75 4:30 1:30</p>	<p>CBS-2132 right side completing drip delay, left side ready for next brew</p> 

Programming- operator access programming

- The FETCO CBS-2130 brewers have four brew batch menus per side.
- They are preprogrammed with basic settings that will operate the equipment as purchased.
- There are two batches each marked "Regular" and two marked "Decaf"
- Most operators prefer a full batch and half batch setting for regular and decaf or specialty coffees. These will need to be programmed by the operator
- Settings are adjustable and the names can be changed. -Batch 1 & 4 cannot be disabled.

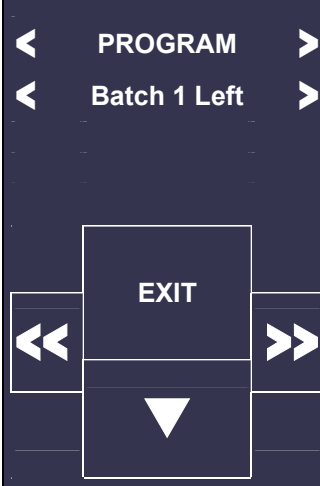
Menu screen displayed	Accessing Programming	Menu screen displayed	Accessing Programming menu screens
 <p>CBS_2130 FETCO © 2012 all rights reserved Ready Touch screen to unlock Heating Filling (FETCO "HOME" screen)</p>	<p>Turn unit "OFF"</p> <p>After 10 second delay: Pre-check will display: "DC voltage calibration for pumps is running...Please wait...Calibration is successfully done".</p> <p>Turn unit "ON" "HOME" Screen on left will appear</p> <p>← Immediately place finger on screen and "HOLD" Screen on right will appear →</p>	 <p>PROGRAM Batch 1 Left EXIT</p>	<p>← Top line is programming category ← Second line displays items for programming</p> <p>Right and left hand arrows will scroll to the screens that display "Program, General, Inputs, Outputs and Other" .</p> <p>Down arrow enters the individual programming items shown below</p>

Programming-category screens: Menu Tree

Programming category screens

To enter: Turn unit "OFF", After 10 second delay, turn unit "ON", (Home Screen will appear), Immediately place finger on screen and "HOLD" PROGRAM Screen (first below) will appear. Use right/left and down arrows to travel through programming. "EXIT" saves settings

PROGRAM Batch 1 Left	GENERAL Tank Temp.	INPUTS Display Inputs	OUTPUTS Left Pump	OTHER Error Codes
Programming Category	Programming Category	Programming Category	Programming Category	Programming Category
PROGRAM	GENERAL	INPUTS	OUTPUTS	OTHER
Items for Programming	Items for Programming	Items for Programming	Items for Programming	Items for Programming
Batch 1 LEFT*	Tank Temp	Display Inputs	Left Pump	Error Codes
Batch 2 Left**	Brew At Temp	Calib Touch Scr	L.Bypass Pump*	Display Errors
Batch 3 Left **	Unit of Meas.		Right Pump	Reset Errors
Batch 4 Left **	Volume		R.Bypass Pump*	Copy Program
Batch 1 RIGHT*	ECO Mode		Fill Valve	From SD to B
Batch 2 Right **	Logo Timeout		Heater	From B to SD
Batch 3 Right **	Brew B.Sensor		Screen	Upload Logo
Batch 4 Right **			*Bypass option is only on 1 gallon airpot version	Res to Factory
Batch Copy				Firmware

Menu Features: Batch Parameters

PROGRAM	Programming Items	Factory set Default	Programming Range	Notes
Batch 1 LEFT*	• Batch Summary	Display Summary		
	• Batch Name	Regular 1(-16)	Choose from list: Regular1	(Regular 1-16) -OR- Write: any name
	• Batch Volume	3.05 liter [1.0-4.7]	3.03 liter 	
	• Brew Time	4:00 mm:ss	4:00 mm:ss 	
	• Spray Pattern	Wide	Wide 	
	• Nr Of Pulses	8	8 	
	• Prewet Perc.	0%	0 % 	
	• Prewet Delay	0:00 mm:ss	1:30 mm:ss 	
	• Bypass Perc.	0%	0 % 	Bypass option is only on 1 gallon airport version
	• Drip Delay	1:30 mm:ss	1:30 mm:ss 	
Batch 2 Left**	**Batch 2-4—Right and Batch2-4—Left may be individually selected-or-entirely deleted			
• Batch ON/OFF	ON		ON 	
• Batch Summary	Display Summary			
• Batch Name	Regular 1		Regular 1-16;Write own name	
• Batch Volume	3.03 liter [0.94-4.73]		ON 	
• Brew Time	4:00 mm:ss		4:00 mm:ss 	
• Spray Pattern	Wide		Wide 	
• Nr Of Pulses	8		8 	
• Prewet Perc.	0%		0 % 	
• Prewet Delay	0:00 mm:ss		0:00 mm:ss 	
• Bypass Perc.	0%		0 % 	Bypass option is only on 1 gallon airport version
• Drip Delay	1:30 mm:ss		1:30 mm:ss 	
Batch 3 Left **	<i>(See Batch 2-Left)</i>			
Batch 4 Left **	<i>(See Batch 2-Left)</i>			
Batch 1 Right *	<i>(See Batch 1-Left)</i>			
Batch 2 Right **	<i>(See Batch 2-Left)</i>			
Batch 3 Right **	<i>(See Batch 2-Left)</i>			
Batch 4 Right **	<i>(See Batch 2-Left)</i>			
Batch Copy	Copy From Batch	L1	L1-L4;R1-R4	
	Copy To Batch	L1	L1-L4;R1-R4	
	Copy?	L1→L2? (example)	NO 	

*Batch 1&4 cannot be disabled. (CBS-2132); *Batch 1 cannot be disabled. (CBS-2131) **Batch can be disabled, and removed from display

GENERAL	Programming Items	Factory set Default	Programming Range (display)	Notes
Tank Temp.		200°F		Correction for high altitude below
Brew at Temp.	“OFF” allows brewing at any temperature.	AUTO		SEE NOTE BELOW!
Units of Meas.	• Temperature	°F		
	• Volume	Liters		
Logo Timeout		1:00 mm:ss		
Brew B. Sensor		NORMAL		

INPUTS	Programming Items	Factory set Default	Programming Range (display)	Notes
Display Inputs	• Input Summery		Brew Basket Sensor <input type="checkbox"/> High Liquid Level probe <input checked="" type="checkbox"/> High Tank Temperature Probe <input checked="" type="checkbox"/> Lower Tank Temperature Probe <input checked="" type="checkbox"/> SD Card Recognized <input type="checkbox"/> USB Drive Recognized <input type="checkbox"/>	USB is for factory setup only
Cal. Touch Scr		Calibrate		If Yes: Follow directions on the touch screen

Altitude (ft.)	Suggested Setting(°F)	Boiling point (° F)
0	200	212.0
500	200	211.1
1000	200	210.2
2000	200	208.4
2500	200	207.5
3000	200	206.6
3500	197	205.7
4000	195	204.8
4500	194	203.9
5000	194	203.0
5500	193	202.0
6000	192	201.1
6500	191	200.2
7000	190	199.3
7500	188	198.3
8000	187	197.4

BREW AT TEMPERATURE DEFINITONS

BREW AT TEMP: AUTO
(DEFAULT: FACTORY PROGRAMMED INTO BREWER)
 This allows the “BREW START” to active. If the hot water tank is at the selected temperature—the brew will start. If the temperature is too low, the brewer will wait until the proper temperature is reached. A screen (example to the right) will display showing a thermometer icon and the tank temperature.
IMPORTANT: ALWAYS have dispenser(s) under the brew baskets when in the BREW AT TEMP mode.

BREW AT TEMP: ON **USER SELECTABLE**
 “BREW START” Batch Section Buttons will not be accessible until tank temperature is at set point. The “BREW START” screens with the Batch Section Buttons become accessible when hot water tank is at the selected temperature. The screen at right displays when the “BREW AT TEMP” is selected.

BREW AT TEMP: OFF **USER SELECTABLE**
 Allows brewing at any temperature above 179°F/82°C. (Not recommended)

BREW AT TEMP: ON **USER SELECTABLE**
 “BREW START” Batch Section Buttons will not be accessible until tank temperature is at set point. The “BREW START” screens with the Batch Section Buttons become accessible when hot water tank is at the selected temperature. The screen at right displays when the “BREW AT TEMP” is selected.

OTHER	Programming Items	Factory set Default	Programming Range (display)	Notes
Error Codes	• Display Errors	(Codes)	1: 2: 3:	Chart is below
	• Reset Errors	(Reset)	Reset ----- YES NO	!!Errors must be corrected and cleared!!
Copy Program	• From SD to B.	SD→ Brewer	SD→ Brewer ----- YES NO	Setup upload ----- Please insert SD card with the setup data!
	• From B to SD	Brewer→ SD	Brewer→ SD ----- YES NO	Setup download ----- Please insert SD card with sufficient space (≥2GB)
Upload Logo		Upload Logo	UPLOAD LOGO Are you sure ----- YES NO	Please insert SD card with logo file!
Res to Factory		Reset to default	Reset to Default Are you sure ----- YES NO	Completely overwrites all user setup, incl. user logo.
Counters	• Display Counters -OR- • Reset Counters	Counters Display Total Counters	All Counters Left Brews 0 Left Brew activated 0 Left Brew [liters] 0 Left Bypass Activated 0 Left Bypass [liters] 0 Right Brews 0 Right Brew activated 0 Right Brew [liters] 0 Right Bypass Activated 0 Right Bypass [liters] 0 Fill valve Activated 0 Fill Valve [liters] 0 Heater Activated 0 Heater "on" time 0 Touch To Return	Resetting will restart counter from zero
	• Reset Counters	Reset All Counters	Reset All Counters Are you sure ----- YES NO	
Firmware	• Firmware Version -Software type	Firmware Version	SW ver. 1.0.2A HW ver BL ver.1.0.1 QP ver. 4.5.01	Displays firmware version
	• Update Firmware	UPDATE	UPDATE ----- YES NO	Firmware upload ----- Please insert SD card with the firmware file!

ERROR CODES

Error code 50: Shorted temperature probe
 Error code 51: Open temperature probe
 Error code 100: Initial Fill Error. Initial fill time was more than 4 minutes after power up.
 Error code 101: Error on refill
 Error code 102: Unwanted fill; possible leak
 Error code 103: Liquid level probe fault
 Error code 201: Heater open, high limit thermostat, or Solid State Relay (SSR) fault

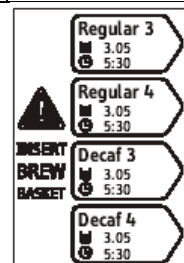

OUTPUTS	Programming Items	Factory set Default	Programming Range (display)	Notes
Left Pump	• Left Pump Test	(Press to test)	TEST Press To Test <input type="checkbox"/>	Runs pump to verify flow. Have container under brewbasket!
” ” ” ”	• L. Pump Calib	Calibrate *Flow Rate	0.49 ----- 0.39 0.59	Factory or service use for flow rate
L.Bypass Pump*	• Left BP Pump Test	(Press to test)	TEST Press To Test <input type="checkbox"/>	Runs pump to verify flow. Have container under brewbasket!
” ” ” ”	• L. BP Pump Calib	Calibrate *Flow Rate	0.49 ----- 0.39 0.59	Factory or service use for flow rate
Right Pump	• Right Pump Test	(Press to test)	TEST Press To Test <input type="checkbox"/>	Runs pump to verify flow. Have container under brewbasket!
” ” ” ”	• R. Pump Calib	Calibrate *Flow Rate	0.49 ----- 0.39 0.59	Factory or service use for flow rate
R.Bypass Pump*	• Right BP Pump Test	(Press to test)	TEST Press To Test <input type="checkbox"/>	Runs pump to verify flow. Have container under brewbasket!
” ” ” ”	• R. BP Pump Calib	Calibrate *Flow Rate	0.49 ----- 0.39 0.59	Factory or service use for flow rate
Fill Valve	• Fill Valve Test	(Press to test)	TEST Press To Test <input type="checkbox"/>	Operates fill valve. Have container under both brewbaskets!
Heater	• Heater Test	(Press to test)	TEST Press To Test <input type="checkbox"/>	Energizes Heater(s) Use for servicing.
Screen	• Screen Contrast	Contrast	8 ----- 1 10	
	• S. Brightness	Brightness	8 ----- 1 10	

*Bypass option is only on 1 gallon airpot version

***How to calculate flow rate**

Measured → **2.90**

$$\frac{\quad}{\quad} = 0.96$$
Set Point → **3.00**

If flow rate setting is 0.49
Then new flow rate is
0.49 X 0.96=**0.47**

By entering the new flow rate number into the brewer, the software will correct the discrepancy in the pump.

Hot water convenience tap

1. The CBS-2130 coffee brewers include a hot water convenience tap for single cup beverage purposes.
2. Single use delivery volume should not exceed maximum 16fl.oz/473cc.
3. Water dispensed from this faucet is very hot, up to 205°F/96°C

Adjustable spray pattern

This FETCO equipment features digitally adjustable spray patterns for perfect penetration

FETCO CBS-2131 and CBS-2132 coffee brewers feature digitally adjustable spray patterns for perfect penetration. All batches can be set for wide, middle or narrow spray patterns of the hot brew water that showers the coffee bed in the brewbasket. The turbulence created by the spray pattern combined with variable pulses is infinitely adjustable for desired flavor extraction of individual roasts and grinds of any coffee variety.

The default setting for all batches is WIDE. The brewer software calculates and corrects to achieve proper volume based on the flow rate changes of the spray pattern.

Error Codes

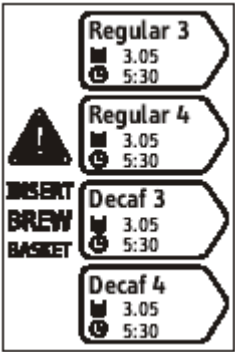
Code	Description	Possible Cause	Corrective Action	How to Clear Error Codes
050	Shorted temperature probe	Probe failure.	Replace probe.	<p>CLEAR FAULT, make repairs as required Below is the only way to clear error codes</p> <p>1) Enter "PROGRAMMING"</p> <p>2) Scroll left to "OTHER"</p> <p>3) Scroll down to "ERROR CODES"</p> <p>4) Scroll down to "Display Errors"</p> <p>5) Scroll left to "Reset Errors"</p> <p>6) Scroll down to "Reset"</p> <p>7) Follow directions shown on screen.</p> <p>Toggleing ON/OFF switch <u>will not</u> clear error codes.</p> <p>Error codes must be cleared!</p>
051	Open temperature probe.	Bad probe connection, or probe failure.	Check all connections. Replace probe if necessary.	
100	Initial Fill Error. Initial fill time was more than 4 minutes after power up.	Water supply flow rate is too low.	Watch for short potting during brew cycle. Investigate cause of low flow rate. (Clogged water filter...)	
101	Error on refill Tank did not refill within 3 minutes.	Water supply flow rate is too low.	Watch for short potting during brew cycle. Investigate cause of low flow rate. (Clogged water filter...)	
102	Unwanted fill;	Possible leak in tank, fitting, or valve.	Check inside of machine for leaks.	
103	Liquid level probe fault	Probe fouled or shorts	Clean, check all connections. Replace probe if necessary.	
201	Heater open, high limit thermostat, or Solid State Relay (SSR) fault	SSR, High Limit, or heating element failure.	Check and replace heating elements if necessary.	
 <p>INSERT BREW BASKET</p>				<p>Brewbasket must be in place</p> <p>Insert brewbasket</p>

Designs, materials, specifications, physical dimensions, firmware and software protocol for equipment or replacement parts are subject to review and change by FETCO without notice

Airpot use instructions and cleaning



Dispenser Diagram



D041 (3 liter) and
D063 (1 gallon) Airpot

DESCRIPTION : Dispenser Diagram

The FETCO D041 (3 liter) and D063 (1 gallon) airpots are lever type, air pressure evacuated beverage dispenser featuring double-wall, vacuum insulated construction.

The hermetically sealed vacuum double-wall construction provides excellent heat or cold retention, while the stainless steel outer and inner liners provide robust durability.

PARTS :

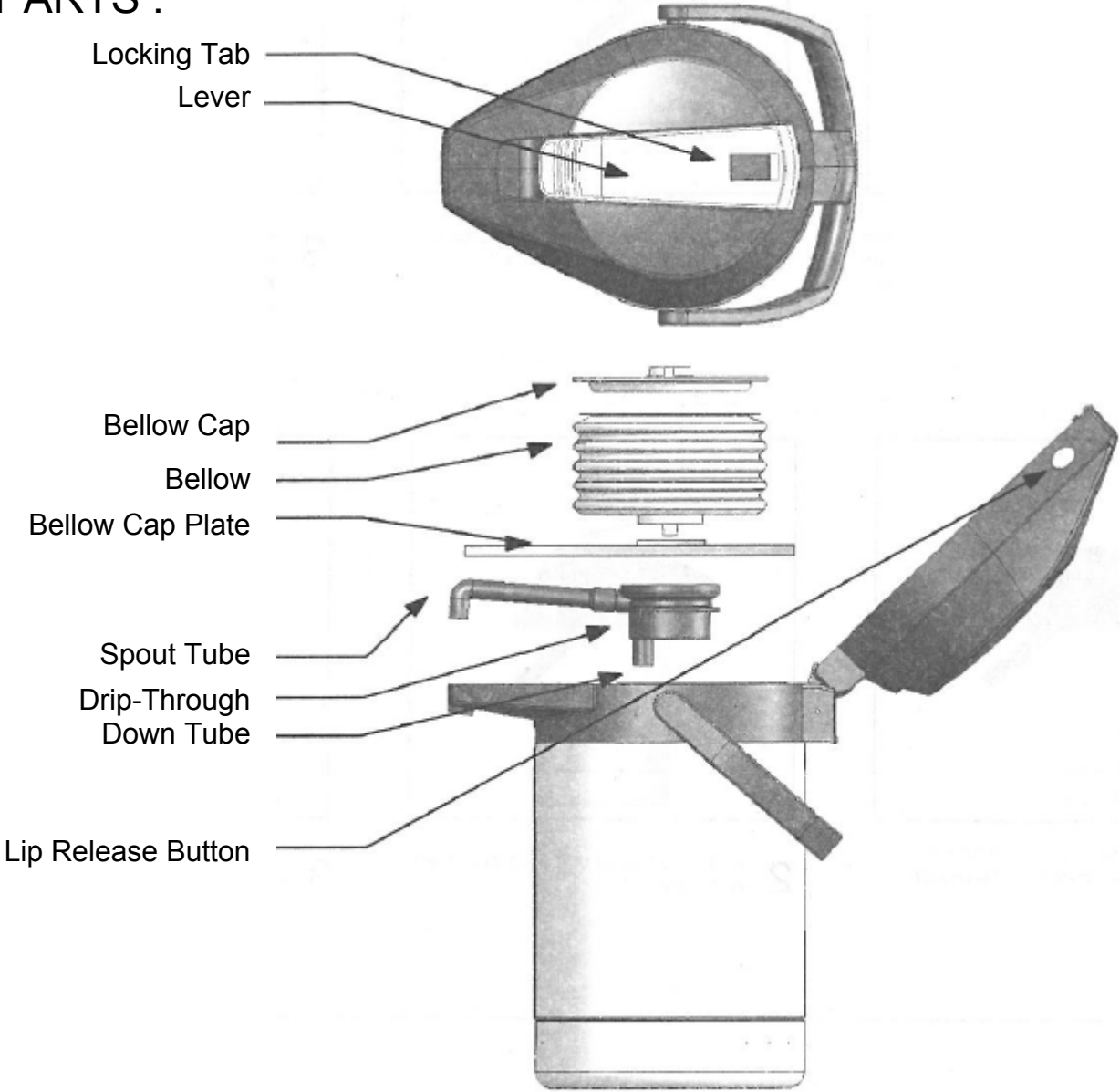

Dispenser Operation Instructions



FETCO
DRIVEN TO INNOVATION®

D041 (3 liter) and
D063 (1 gallon) Airpot

To Fill :

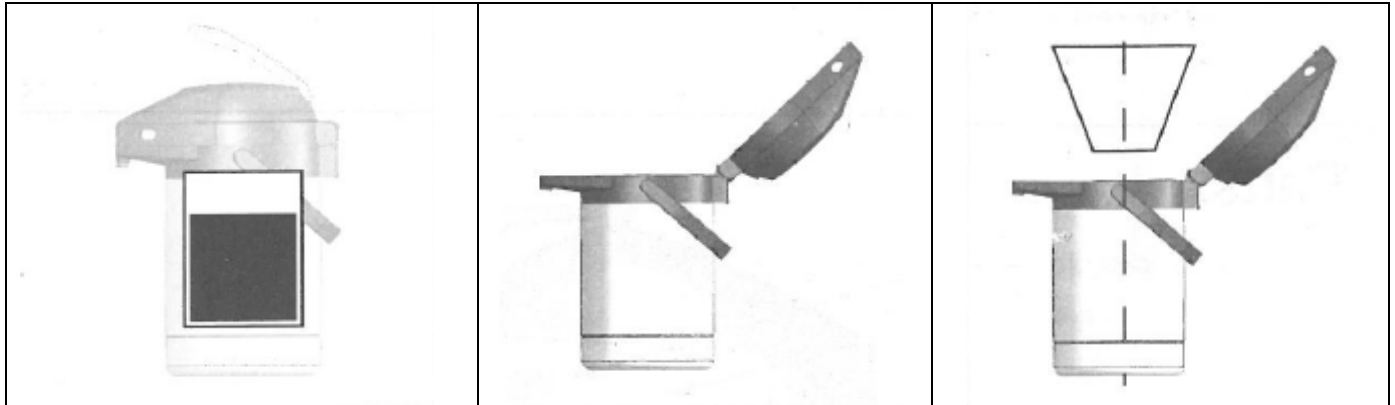

- 1 Set brewer to dispense the proper amount into the airpot :
3 liters (FETCO D041)
-or-
1gallon (FETCO D063)
- 2 Squeeze the **Lid Release Buttons** to release the lid.

Swing the lid completely backwards
- 3 Place the airpot under the brewer against the airpot dispenser Locator (if featured).
Align the center of the airpot Drip-Through with the outlet of the brewbasket.

To Dispense:



- 1 After the brew cycle is completed:
Remove the airpot from under the brewbasket and close the lid.
- 2 Lift the handle up until the Lever Lock drops into position, and engages the pump mechanism.
- 3 Push the lever downwards multiple times to dispense the desired amount

Dispenser Cleaning & Maintenance



FETCO
DRIVEN TO INNOVATION

D041 (3 liter) and
D063 (1 gallon) Airpot

To Clean :

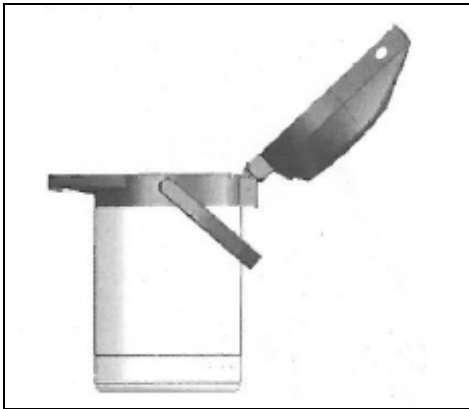

1 Squeeze the Lid Release Buttons to release the lid. Press the Lid Detach Button that will completely detach the lid. Remove the Lid Cover.



2 Remove the **Drip-Through** Detach the **Down-Tube** and the **Spout-Tube**. Clean with warm water, detergent and a brush. Proprietary airpot cleaners may also be used.

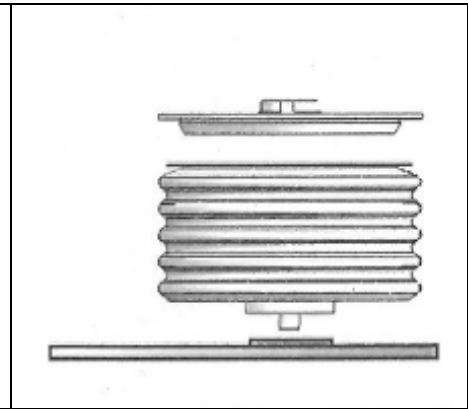

3 Carefully remove the bellows Cap. Handling the parts gently, clean the **Bellows**, **Bellows Cap**, and **Bellow Cap Plate** with warm water, and non-abrasive mild detergent.

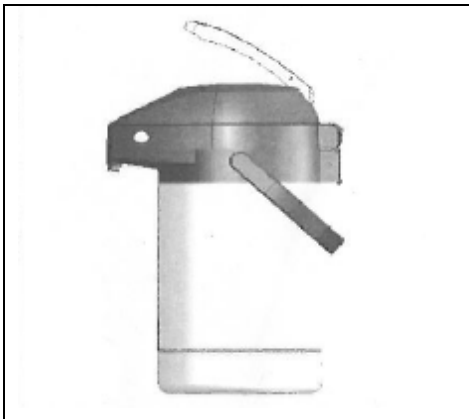

4 Clean the interior of the tank with warm water, detergent and a brush. Proprietary airpot cleaners may also be used. **Do not put the airpot into an automatic dishwasher. Do not allow solutions containing chlorine to remain in tank.**

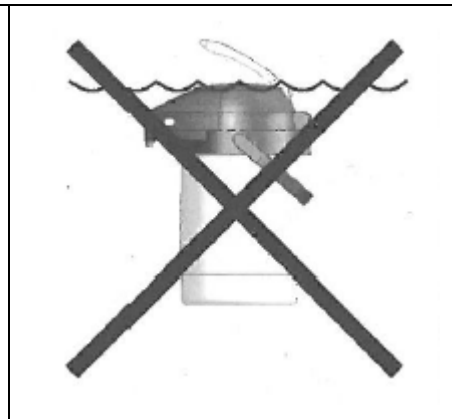

5 Clean the exterior of the unit with warm water, non-abrasive mild detergent. **Do not submerge the unit in water**

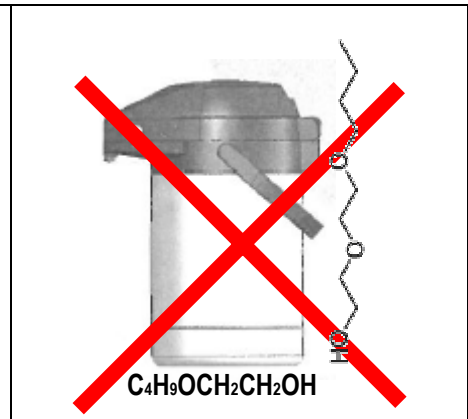

6 Do not use petroleum based or organic cleaners on food equipment. **Never use cleaners or polishes formulated with the solvent diethylene glycol butyl ether(DGBE) on any equipment.**

FETCO® CBS-2130 COFFEE BREWING SYSTEM

Complete Commercial Parts Listing

For CBS-2131 and CBS-2132 Model Range
Includes types for the 3 liter and 1 gallon airpot dispensers

NEW September, 2012

Please see our website-www.fetco.com for the most up to date listings and additional parts and service information

Parts diagrams, bill of materials lists

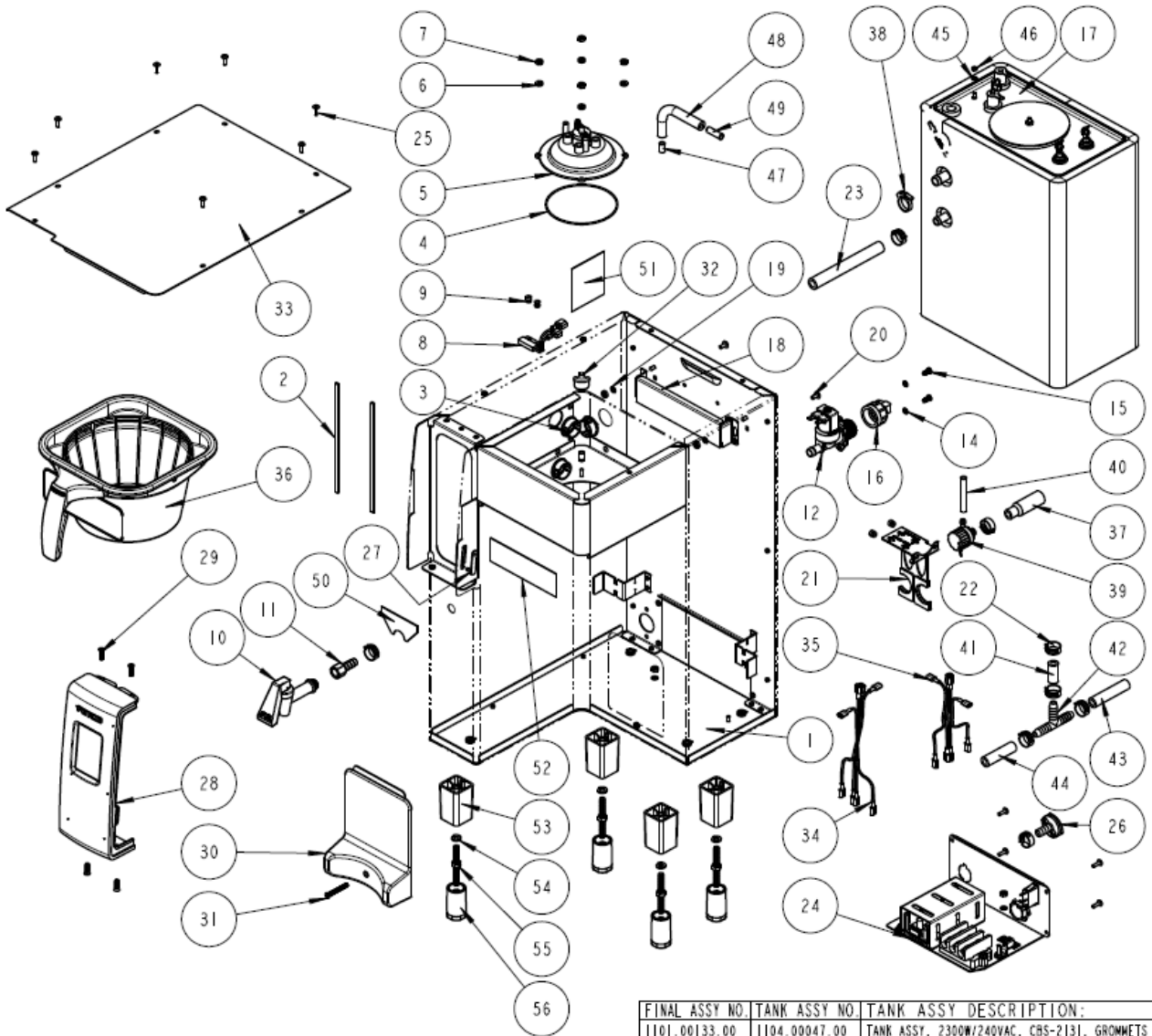

FINAL ASSY NO.	TANK ASSY NO.	TANK ASSY DESCRIPTION:
1101.00133.00	1104.00047.00	TANK ASSY, 2300W/240VAC, CBS-2131, GROMMETS
1101.00135.00	1104.00048.00	TANK ASSY, 3000W/240VAC, CBS-2131, GROMMETS

Drawing 1101.00128.00 CBS-2131ASSEMBLY, 1gallon NO BYPASS, 2.3kW/120VAC			
Ref#	Qty	Part number	Description
1	1	1111.00030.00	WELDMENT BODY, CBS-2131
2	2	1024.00049.00	EDGE PROTECTOR, 7.00"LG, CBS-2130
3	3	1086.00004.00	BUSHING, SNAP, 1" MOUNTING HOLE
4	1	1024.00017.00	O'RING, 3.739" ID X 0.070" CS, 70 DURO, BUNA "N", FDA
5	1	1102.00183.00	SPRAY HOUSING ASSEMBLY, CBS-2130
6	4	1083.00010.00	WASHER, #10 SCREW W/NEOPRENE-BONDED SEAL
7	8	1084.00006.00	NUT, 8-32 18-8 HEX MACHINE SCREW
8	1	1102.00113.00	SWITCH, REED, ASSEMBLY
9	4	1029.00006.00	#4-40 NYLON FINGER NUT
10	1	1071.00010.00	FAUCET HPSC-BR-8 REGULAR HANDLE
11	1	1031.00003.00	FITTING, BARB 3/8"ID x 1/4" FPT
12	1	1057.00043.00	SOLENOID VALVE, SINGLE, 180 DEG, 24VDC
13	1		
14	2	1083.00005.00	WASHER, M4 18-8 INTERNAL TOOTH LOCKWASHER
15	2	1082.00010.00	SCREW, M4x10 ZINC PLATED PAN PHILLIPS MACHINE
16	1	1102.00164.00	ADAPTER ASSY, 3/4" BSP X 1/4 SAE FLARE
17	1	1104.00043.00	TANK ASSY, 2300W/120VAC, CBS-2131, GROMMETS
18	1	1112.00163.00	WELDMENT TANK LOCK BRACKET, CBS-2100
19	4	1083.00011.00	WASHER, #8 SCREW SIZE, INTERNAL TOOTH LOCK
20	2	1082.00023.00	SCREW, #8-32 X 3/8 TRUSS HD PHIL., MACHINE
21	1	1102.00187.00	PUMP BRACKET AND HOLDER ASSEMBLY
22	9	1086.00003.00	UNICLAMP, 15.9 HOSE OD CLAMP
23	1	1025.00063.00	TUBE, 5/8"OD X 3/8"ID X 8.50"LG
24	1	1102.00181.00	ASSEMBLY BACK PANEL, CBS-2130
25	11	1082.00017.00	SCREW, # 6-32 X 1/2" TRUSS HD PHIL., MACHINE
26	1	1023.00147.00	PLUG, TANK SERVICE DRAIN FOR 18GA AND UP BODY
27	1	1024.00040.00	CARD PLUG, HWD-2100
28	1	1102.00190.00	ASSEMBLY FRONT PANEL, CBS-2100
29	4	1082.00058.00	SCREW, # 8-32 X 5/8, FLAT HD, PH, 18-8 SS
30	1	1102.00182.00	ASSEMBLY, LOCATOR CBS-2130
31	1	1082.00065.00	SCREW #8-32 X 1 1/2", FLAT HD PH, 18-8 SS
32	1	1023.00159.00	CORNER INSERT
33	1	1112.00168.00	WELDMENT, TOP COVER, CBS-2131
34	1	1402.00034.00	HARNESS, HIGH AMP, CBS-2131
35	1	1402.00035.00	HARNESS, LOW AMP, CBS-2131
36	1	B012280B1	BB ASSY, 13"X5", .280" DIA. HOLE, BLK HNDL
37	1	1024.00052.00	CONNECTOR, BREW PUMP
38	1	1086.00002.00	CLAMP, HOSE, SIZE "G" NYLON
39	1	1055.00001.00	PUMP, HOT LIQUID
40	1	1025.00012.00	TUBE, 5/16"OD X 3/16"ID X 11.00"LG
41	1	1025.00061.00	TUBE, 9/16"OD X 5/16"ID X 2.75"LG
42	1	1029.00002.00	FITTING, HOSE BARB TEE, SIZE 3/8" , NYLON
43	1	1025.00058.00	TUBE, 9/16"OD X 5/16"ID X 25.00"LG
44	1	1025.00060.00	TUBE, 9/16"OD X 5/16"ID X 3.25"LG
45	1	1083.00009.00	WASHER, #6 SCREW , INTL TOOTH LOCKWASHER
46	1	1084.00010.00	NUT, HEX, #6-32, UNDERSIZED, ZINC PLATED
47	1	1025.00006.00	TUBE, VENT SUPPORT, 5/16" OD X 3/16" ID X 1/2" LG
48	1	1025.00064.00	TUBE, 1/2 OD X 1/4 ID X 9.00 LG
49	1	1013.00073.00	TUBE, 5/16" OD, 1" LONG
50	1	1046.00006.00	LABEL, WARNING, "HOT WATER FAUCET"
51	1	1044.00004.00	LABEL, DANGER, HIGH VOLTAGE
52	1	1046.00003.00	LABEL, CSD WARNING, 1.5" X 5.0"
53	4	1023.00163.00	LEG BODY, CBS-2130
54	4	1083.00021.00	WASHER, 1/4" SCREW SIZE, SPRING LOCK
55	4	1112.00158.00	WELDMENT, LEG ROD, CBS-2130
56	4	1021.00017.00	LEG INSERT THREADED, CBS-2130

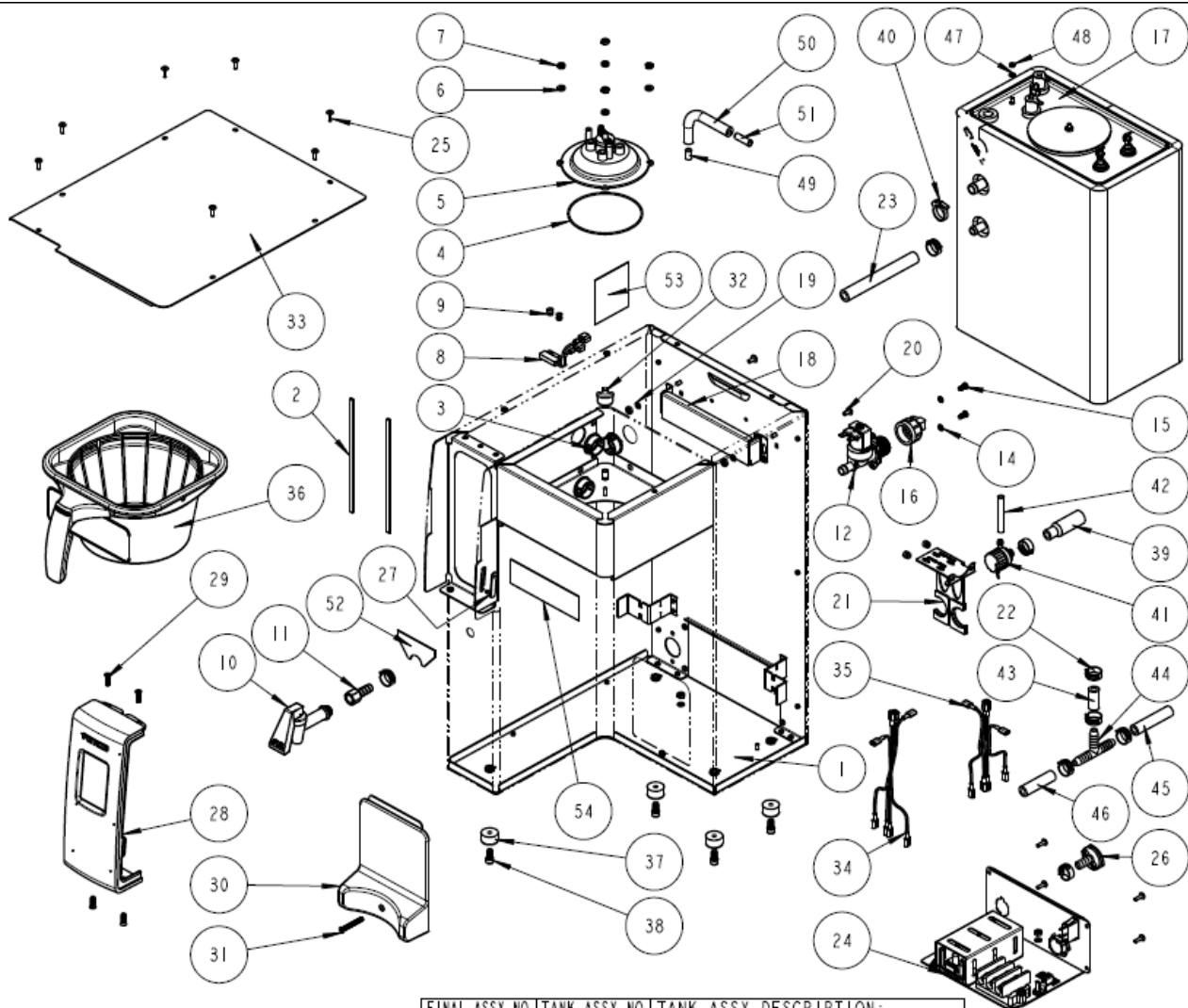

FINAL ASSY NO.	TANK ASSY NO.	TANK ASSY DESCRIPTION:
1101.00137.00	1104.00045.00	TANK ASSY, 1500W/120VAC, CBS-2131, GROMMETS
1101.00138.00	1104.00046.00	TANK ASSY, 1700W/120VAC, CBS-2131, GROMMETS
1101.00139.00	1104.00047.00	TANK ASSY, 2300W/240VAC, CBS-2131, GROMMETS
1101.00140.00	1104.00048.00	TANK ASSY, 3000W/240VAC, CBS-2131, GROMMETS

ANY REPRODUCTION OF THIS OR ANY OTHER MATERIAL HEREIN WITHOUT PERMISSION OF PENTON IS PROHIBITED.

Drawing 1101.00127.00		CBS-2131ASSEMBLY, 3 Liter NO BYPASS , 2.3kW/120VAC	
Ref#	QTY	PART NO	DESCRIPTION
1	1	1111.00030.00	WELDMENT BODY, CBS-2131
2	2	1024.00049.00	EDGE PROTECTOR, 7.00"LG, CBS-2130
3	3	1086.00004.00	BUSHING, SNAP, 1" MOUNTING HOLE
4	1	1024.00017.00	O'RING, 3.739" ID X 0.070" CS, 70 DURO, BUNA
5	1	1102.00183.00	SPRAY HOUSING ASSEMBLY, CBS-2130
6	4	1083.00010.00	WASHER, #8 SCREW SIZE W/NEOPRENE- BONDED SEAL
7	8	1084.00006.00	NUT, 8-32 18-8 HEX MACHINE SCREW
8	1	1102.00113.00	SWITCH, REED, ASSEMBLY
9	4	1029.00006.00	#4-40 NYLON FINGER NUT
10	1	1071.00010.00	FAUCET HPSC-BR-8 REGULAR HANDLE
11	1	1031.00003.00	FITTING, BARB 3/8"ID x 1/4" FPT
12	1	1057.00043.00	SOLENOID VALVE, SINGLE, 180 DEG, 24VDC
13	1		
14	2	1083.00005.00	WASHER, M4 18-8 INTERNAL TOOTH LOCKWASHER
15	2	1082.00010.00	SCREW, M4x10 ZINC PLATED PAN PHILLIPS MACHINE
16	1	1102.00164.00	ADAPTER ASSY, 3/4" BSP X 1/4 SAE FLARE
17	1	1104.00043.00	TANK ASSY, 2300W/120VAC, CBS-2131, GROMMETS
18	1	1112.00163.00	WELDMENT TANK LOCK BRACKET, CBS-2100
19	4	1083.00011.00	WASHER, #8 SCREW SIZE, INTERNAL TOOTH LOCK
20	2	1082.00023.00	SCREW, #8-32 X 3/8 TRUSS HD PHIL., MACHINE
21	1	1102.00187.00	PUMP BRACKET AND HOLDER ASSEMBLY
22	9	1086.00003.00	UNICLAMP, 15.9 HOSE OD CLAMP
23	1	1025.00063.00	TUBE, 5/8"OD X 3/8"ID X 8.50"LG
24	1	1102.00181.00	ASSEMBLY BACK PANEL, CBS-2130
25	11	1082.00017.00	SCREW, # 6-32 X 1/2" TRUSS HD PHIL., MACHINE
26	1	1023.00147.00	PLUG, TANK SERVICE DRAIN FOR 18GA AND UP BODY
27	1	1024.00040.00	CARD PLUG, HWD-2100
28	1	1102.00190.00	ASSEMBLY FRONT PANEL, CBS-2100
29	4	1082.00058.00	SCREW, # 8-32 X 5/8, FLAT HD, PH, 18-8 SS
30	1	1102.00182.00	ASSEMBLY, LOCATOR CBS-2130
31	1	1082.00065.00	SCREW #8-32 X 1 1/2", FLAT HD PH, 18-8 SS
32	1	1023.00159.00	CORNER INSERT
33	1	1112.00168.00	WELDMENT, TOP COVER, CBS-2131
34	1	1402.00034.00	HARNESS, HIGH AMP, CBS-2131
35	1	1402.00035.00	HARNESS, LOW AMP, CBS-2131
36	1	B012280B1	BB ASSY, 13"X5", .280" DIA. HOLE, BLK HNDL
37	4	1073.00008.00	FOOT, CBS-2130
38	4	1082.00066.00	SCREW 1/4-20 X 1/2", SOCKED HD CUP
39	1	1024.00052.00	CONNECTOR, BREW PUMP
40	1	1086.00002.00	CLAMP, HOSE, SIZE "G" NYLON
41	1	1055.00001.00	PUMP, HOT LIQUID
42	1	1025.00012.00	TUBE, 5/16"OD X 3/16"ID X 11.00"LG
43	1	1025.00061.00	TUBE, 9/16"OD X 5/16"ID X 2.75"LG
44	1	1029.00002.00	FITTING, HOSE BARB TEE, SIZE 3/8" , NYLON
45	1	1025.00058.00	TUBE, 9/16"OD X 5/16"ID X 25.00"LG
46	1	1025.00060.00	TUBE, 9/16"OD X 5/16"ID X 3.25"LG
47	1	1083.00009.00	WASHER, #6 SCREW , INTL TOOTH LOCKWASHER
48	1	1084.00010.00	NUT, HEX, #6-32, UNDERSIZED, ZINC PLATED
49	1	1025.00006.00	TUBE, VENT SUPPORT, 5/16" OD X 3/16" ID X 1/
50	1	1025.00064.00	TUBE, 1/2 OD X 1/4 ID X 9.00 LG
51	1	1013.00073.00	TUBE, 5/16" OD, 1" LONG
52	1	1046.00006.00	LABEL, WARNING, "HOT WATER FAUCET"
53	1	1044.00004.00	LABEL, DANGER, HIGH VOLTAGE
54	1	1046.00003.00	LABEL, CSD WARNING, 1.5" X 5.0"

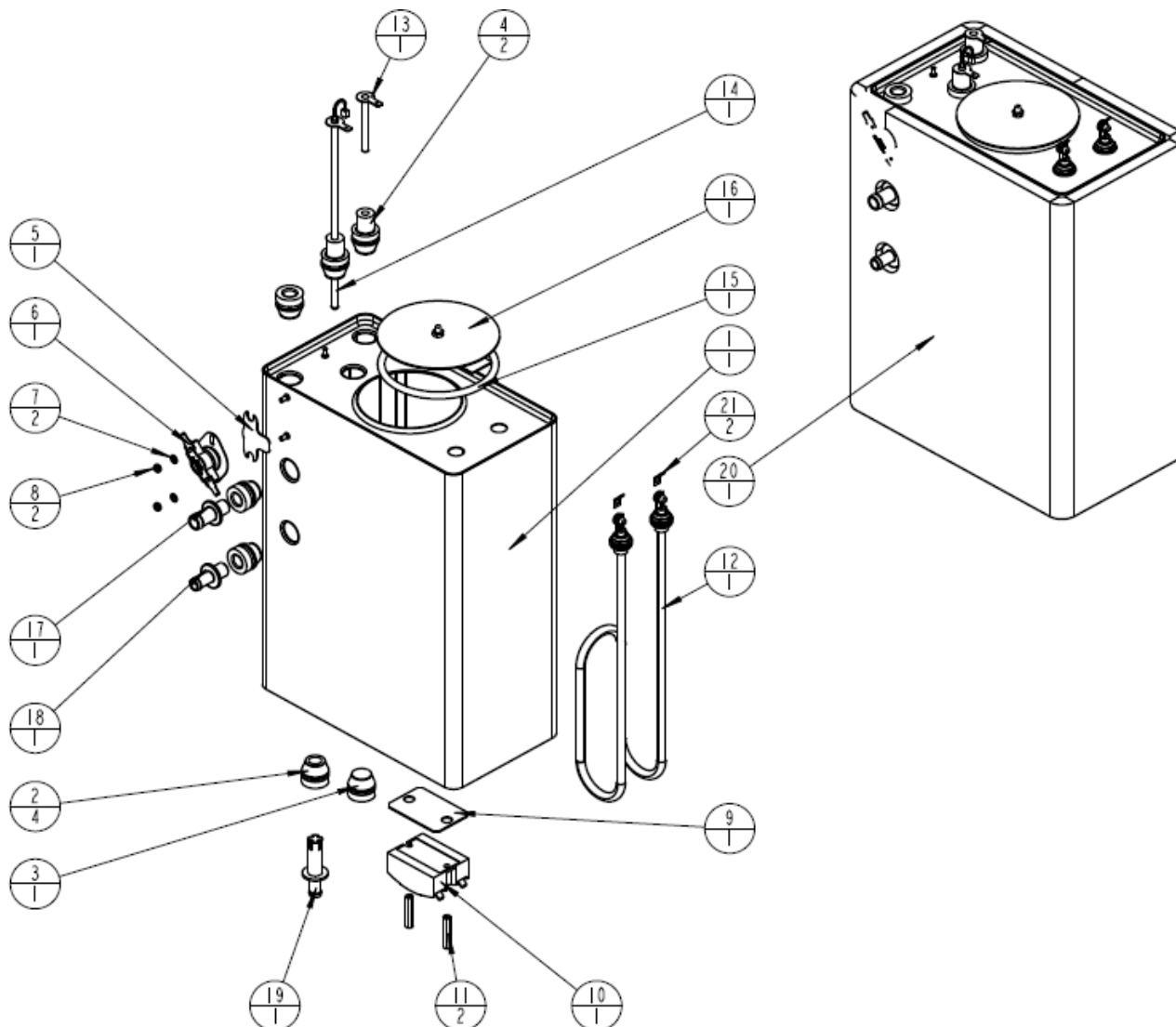

Drawing 1104.00043.00 TANK ASSY, 2300W/120VAC, CBS-2131, GROMMETS			
Ref#	QTY	PART NO	DESCRIPTION
1	1	1114.00066.00	WELDMENT TANK CBS-2131, GROMMET DESIGN
2	4	1024.00050.00	GROMMET, SILICONE, 11.4mm ID
3	1	1024.00051.00	GROMMET, SILICONE, BLANK
4	2	1024.00053.00	GROMMET, SILICONE, LL & TEMP. PROBES
5	1	1003.00005.00	BRACKET, ONE SHOT THERMOSTAT
6	1	1053.00003.00	THERMOSTAT, SINGLE SHOT, 240V/40A
7	2	1083.00009.00	WASHER, #6 SCREW, INTL TOOTH LOCKWASHER
8	2	1084.00010.00	NUT, HEX, #6-32, UNDERSIZED, ZINC PLATED
9	1	1003.00140.00	ALUMINUM BRACKET FOR SSR
10	1	1052.00014.00	ASSEMBLY RELAY, SOLID STATE, 25A/230V
11	2	1081.00042.00	STANDOFF, 6-32 x1.25 LG., 1/4 HEX WIDTH
12	1	1107.00021.00	HEATER ASSEMBLY, IMMERSION 1500W/120VAC
12	1	1107.00022.00	HEATER ASSEMBLY, IMMERSION 1700W/120VAC
12	1	1107.00019.00	HEATER ASSEMBLY, IMMERSION 2300W/120VAC
12	1	1107.00020.00	HEATER ASSEMBLY, IMMERSION 2300W/240VAC
12	1	1107.00018.00	HEATER ASSEMBLY, IMMERSION 3000W/240VAC
13	1	1112.00002.00	PROBE WELDMENT, WATER LEVEL 2.25" LG
14	1	1102.00161.00	PROBE ASSEMBLY, TEMP. AND LLC, HWD-2100
15	1	1024.00007.00	O-RING, DASH #344, TANK COVER
16	1	1102.00007.00	TANK COVER ASSEMBLY
17	1	1023.00167.00	FITTING, BREW, GROMMET DESIGN
18	1	1023.00168.00	FITTING, HOT WATER, GROMMET DESIGN
19	1	1023.00166.00	FITTING, COLD WATER INLET, GROMMET DESIGN
20	1	1022.00056.00	TANK INSULATION, CBS-2131e, GROMMET DESIGN

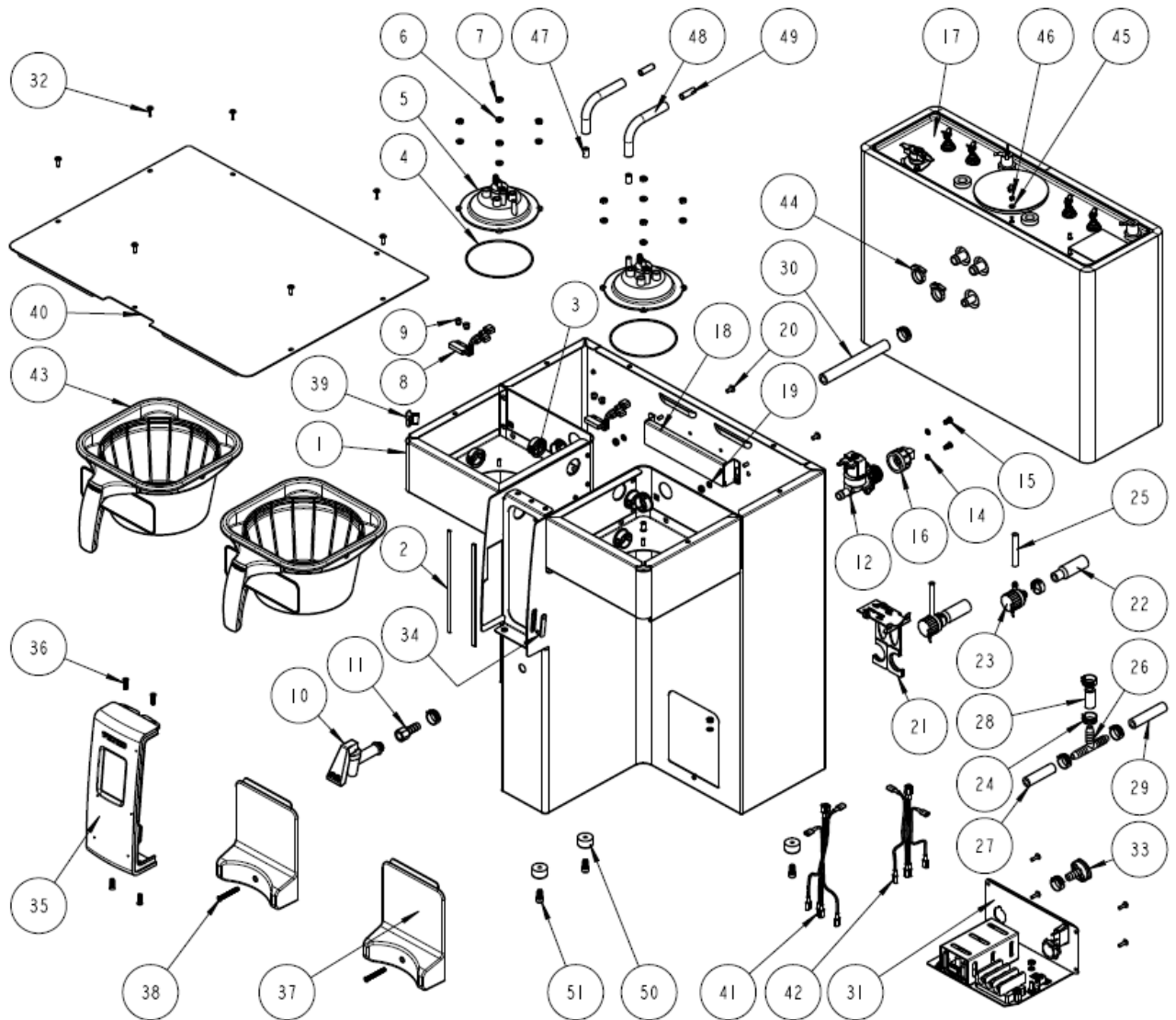

Drawing 1101.00132.00 CBS-2132-3 Liter NO BYPASS 2 X 3kW/240VAC			
Ref#	QTY	PART NO	DESCRIPTION
1	1	1111.00029.00	WELDMENT BODY, CBS-2132
2	2	1024.00049.00	EDGE PROTECTOR, 7.00"LG, CBS-2130
3	6	1086.00004.00	BUSHING, SNAP, 1" MOUNTING HOLE
4	2	1024.00017.00	O'RING, 3.739" ID X 0.070" CS, 70 DURO, BUNA
5	2	1102.00183.00	SPRAY HOUSING ASSEMBLY, CBS-2130
6	8	1083.00010.00	WASHER, #8 SCREW SIZE W/NEOPRENE- BONDED SEAL
7	12	1084.00006.00	NUT, 8-32 18-8 HEX MACHINE SCREW
8	2	1102.00113.00	SWITCH, REED, ASSEMBLY
9	6	1029.00006.00	#4-40 NYLON FINGER NUT
10	1	1071.00010.00	FAUCET HPSC-BR-8 REGULAR HANDLE
11	1	1031.00003.00	FITTING, BARB 3/8"ID x 1/4" FPT
12	1	1057.00043.00	SOLENOID VALVE, SINGLE, 180 DEG, 24VDC
13	1		
14	2	1083.00005.00	WASHER, M4 18-8 INTERNAL TOOTH LOCKWASHER
15	2	1082.00010.00	SCREW, M4x10 ZINC PLATED PAN PHILLIPS MACHINE
16	1	1102.00164.00	ADAPTER ASSY, 3/4" BSP X 1/4 SAE FLARE
17	1	1104.00044.00	TANK ASSY, 2 X 3000W/240VAC, CBS-2132, GROMMETS
18	1	1112.00163.00	WELDMENT TANK LOCK BRACKET, CBS-2100
19	4	1083.00011.00	WASHER, #8 SCREW SIZE, INTERNAL TOOTH LOCK
20	2	1082.00023.00	SCREW, #8-32 X 3/8 TRUSS HD PHIL., MACHINE
21	1	1102.00187.00	PUMP BRACKET AND HOLDER ASSEMBLY
22	2	1024.00052.00	CONNECTOR, BREW PUMP
23	2	1055.00001.00	PUMP, HOT LIQUID
24	10	1086.00003.00	UNICLAMP, 15.9 HOSE OD CLAMP
25	2	1025.00012.00	TUBE, 5/16"OD X 3/16"ID X 11.00"LG
26	1	1029.00002.00	FITTING, HOSE BARB TEE, SIZE 3/8" , NYLON
27	1	1025.00060.00	TUBE, 9/16"OD X 5/16"ID X 3.25"LG
28	1	1025.00061.00	TUBE, 9/16"OD X 5/16"ID X 2.75"LG
29	1	1025.00058.00	TUBE, 9/16"OD X 5/16"ID X 25.00"LG
30	1	1025.00063.00	TUBE, 5/8"OD X 3/8"ID X 8.50"LG
31	1	1102.00181.00	ASSEMBLY BACK PANEL, CBS-2130
32	11	1082.00017.00	SCREW, # 6-32 X 1/2" TRUSS HD PHIL., MACHINE
33	1	1023.00147.00	PLUG, TANK SERVICE DRAIN FOR 18GA AND UP BODY
34	1	1024.00040.00	CARD PLUG, HWD-2100
35	1	1102.00190.00	ASSEMBLY FRONT PANEL, CBS-2100
36	4	1082.00058.00	SCREW, # 8-32 X 5/8, FLAT HD, PH, 18-8 SS
37	2	1102.00182.00	ASSEMBLY, LOCATOR CBS-2130
38	2	1082.00065.00	SCREW #8-32 X 1 1/2", FLAT HD PH, 18-8 SS
39	2	1023.00159.00	CORNER INSERT
40	1	1112.00167.00	WELDMENT, TOP COVER, CBS-2132
41	1	1402.00032.00	HARNESS, HIGH AMP, CBS-2132
42	1	1402.00033.00	HARNESS, LOW AMP, CBS-2132
43	2	B012280B1	BB ASSY, 13"X5", .280" DIA. HOLE, BLK HNDL
44	2	1086.00002.00	CLAMP, HOSE, SIZE "G" NYLON
45	1	1083.00009.00	WASHER, #6 SCREW , INTL TOOTH LOCKWASHER
46	1	1084.00010.00	NUT, HEX, #6-32, UNDERSIZED, ZINC PLATED
47	2	1025.00006.00	TUBE, VENT SUPPORT, 5/16" OD X 3/16" ID X 1/
48	2	1025.00064.00	TUBE, 1/2 OD X 1/4 ID X 9.00 LG
49	2	1013.00073.00	TUBE, 5/16" OD, 1" LONG
50	3	1073.00008.00	FOOT, CBS-2130
51	3	1082.00066.00	SCREW 1/4-20 X 1/2", SOCKED HD CUP

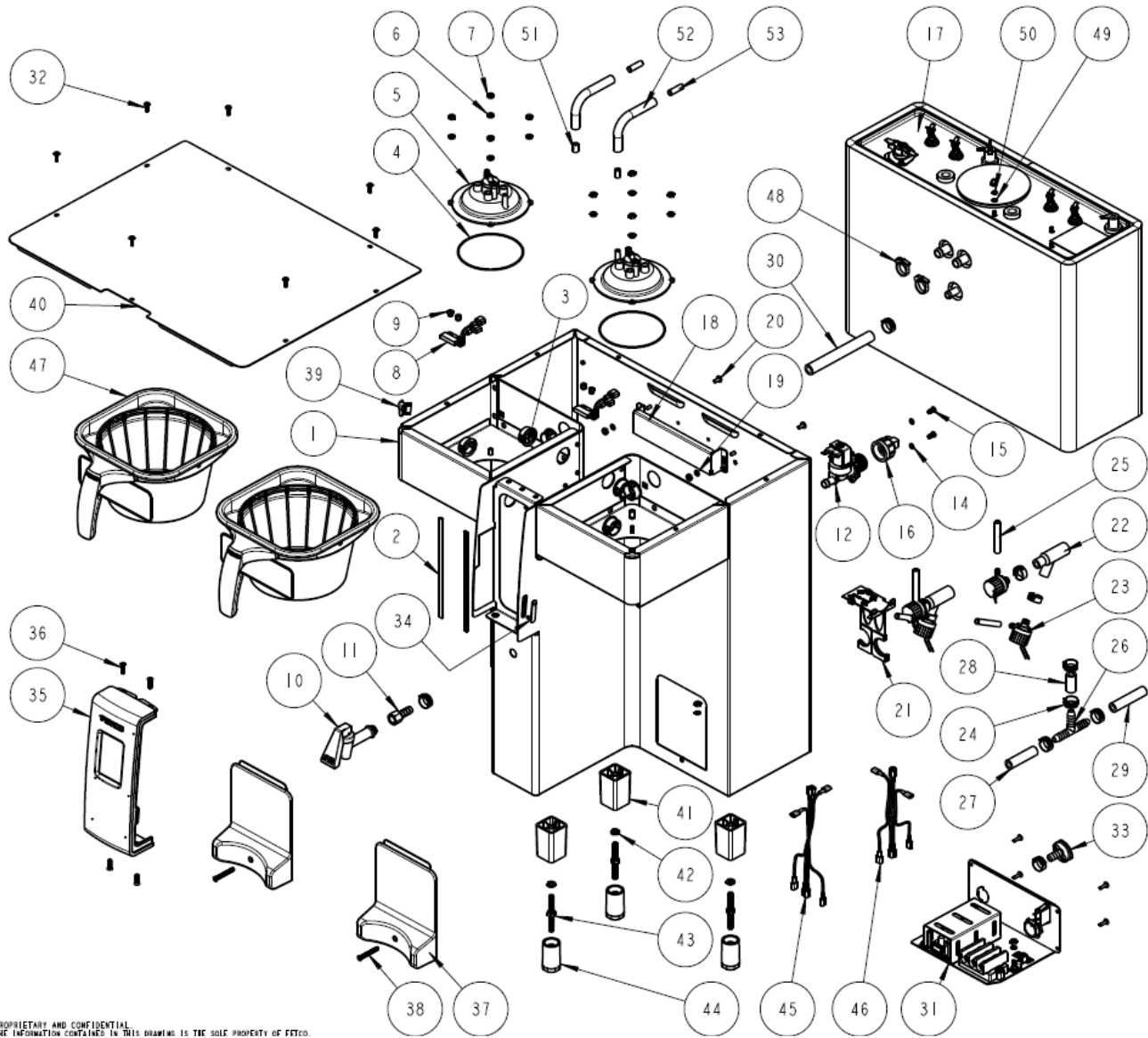

PROPRIETARY AND CONFIDENTIAL
 THE INFORMATION CONTAINED IN THIS DRAWING IS THE SOLE PROPERTY OF FETCO.

Ref#	Qty		1101.00131.00 CBS-2132, 2 X 3kW/240VAC, 1gal BYPASS
1	1	1111.00029.00	WELDMENT BODY, CBS-2132
2	2	1024.00049.00	EDGE PROTECTOR, 7.00"LG, CBS-2130
3	6	1086.00004.00	BUSHING, SNAP, 1" MOUNTING HOLE
4	2	1024.00017.00	O'RING, 3.739" ID X 0.070" CS, 70 DURO, BUNA
5	2	1102.00183.00	SPRAY HOUSING ASSEMBLY, CBS-2130
6	8	1083.00010.00	WASHER, #10 SCREW W/NEOPRENE-BONDED SEAL
7	12	1084.00006.00	NUT, 8-32 18-8 HEX MACHINE SCREW
8	2	1102.00113.00	SWITCH, REED, ASSEMBLY
9	6	1029.00006.00	#4-40 NYLON FINGER NUT
10	1	1071.00010.00	FAUCET HPSC-BR-8 REGULAR HANDLE
11	1	1031.00003.00	FITTING, BARB 3/8"ID x 1/4" FPT
12	1	1057.00043.00	SOLENOID VALVE, SINGLE, 180 DEG, 24VDC
13	1		
14	2	1083.00005.00	WASHER, M4 18-8 INTERNAL TOOTH LOCKWASHER
15	2	1082.00010.00	SCREW, M4x10 ZINC PLATED PAN PHILLIPS MACHINE
16	1	1102.00164.00	ADAPTER ASSY, 3/4" BSP X 1/4 SAE FLARE
17	1	1104.00044.00	TANK ASSY, 2 X 3000W/240VAC, CBS-2132, GROMMETS
18	1	1112.00163.00	WELDMENT TANK LOCK BRACKET, CBS-2100
19	4	1083.00011.00	WASHER, #8 SCREW SIZE, INTERNAL TOOTH LOCK
20	2	1082.00023.00	SCREW, #8-32 X 3/8 TRUSS HD PHIL., MACHINE
21	1	1102.00187.00	PUMP BRACKET AND HOLDER ASSEMBLY
22	2	1024.00048.00	Y-CONNECTOR
23	4	1055.00001.00	PUMP, HOT LIQUID
24	12	1086.00003.00	UNICLAMP, 15.9 HOSE OD CLAMP
25	4	1025.00012.00	TUBE, 5/16"OD X 3/16"ID X 11.00"LG
26	1	1029.00002.00	FITTING, HOSE BARB TEE, SIZE 3/8" , NYLON
27	1	1025.00060.00	TUBE, 9/16"OD X 5/16"ID X 3.25"LG
28	1	1025.00061.00	TUBE, 9/16"OD X 5/16"ID X 2.75"LG
29	1	1025.00058.00	TUBE, 9/16"OD X 5/16"ID X 25.00"LG
30	1	1025.00063.00	TUBE, 5/8"OD X 3/8"ID X 8.50"LG
31	1	1102.00181.00	ASSEMBLY BACK PANEL, CBS-2130
32	11	1082.00017.00	SCREW, # 6-32 X 1/2" TRUSS HD PHIL., MACHINE
33	1	1023.00147.00	PLUG, TANK SERVICE DRAIN FOR 18GA AND UP BODY
34	1	1024.00040.00	CARD PLUG, HWD-2100
35	1	1102.00190.00	ASSEMBLY FRONT PANEL, CBS-2100
36	4	1082.00058.00	SCREW, # 8-32 X 5/8, FLAT HD, PH, 18-8 SS
37	2	1102.00182.00	ASSEMBLY, LOCATOR CBS-2130
38	2	1082.00065.00	SCREW #8-32 X 1 1/2", FLAT HD PH, 18-8 SS
39	2	1023.00159.00	CORNER INSERT
40	1	1112.00167.00	WELDMENT, TOP COVER, CBS-2132
41	3	1023.00163.00	LEG BODY, CBS-2130
42	3	1083.00021.00	WASHER, 1/4" SCREW SIZE, SPRING LOCK
43	3	1112.00158.00	WELDMENT, LEG ROD, CBS-2130
44	3	1021.00017.00	LEG INSERT THREADED, CBS-2130
45	1	1402.00032.00	HARNESS, HIGH AMP, CBS-2132
46	1	1402.00033.00	HARNESS, LOW AMP, CBS-2132
47	2	B012280B1	BB ASSY, 13"X5", .280" DIA. HOLE, BLK HNDL
48	2	1086.00002.00	CLAMP, HOSE, SIZE "G" NYLON
49	1	1083.00009.00	WASHER, #6 SCREW , INTL TOOTH LOCKWASHER
50	1	1084.00010.00	NUT, HEX, #6-32, UNDERSIZED, ZINC PLATED
51	2	1025.00006.00	TUBE, VENT SUPPORT, 5/16" OD X 3/16" ID X 1/
52	2	1025.00064.00	TUBE, 1/2 OD X 1/4 ID X 9.00 LG
53	2	1013.00073.00	TUBE, 5/16" OD, 1" LONG

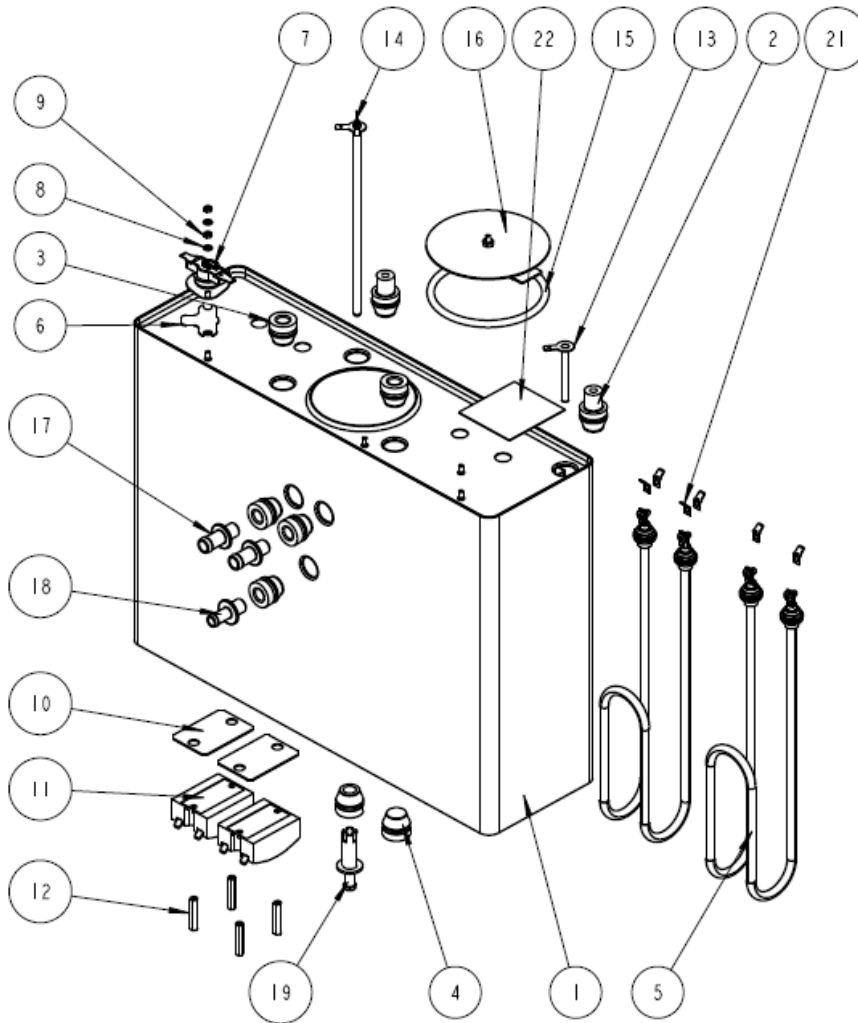

TANK ASSY, 2 X 3000W/240VAC, CBS-2132, GROMMETS			
REF#	QTY	PART NO	DESCRIPTION
1	1	1114.00062.00	WELDMENT TANK CBS-2132e, GROMMET DESIGN
2	2	1024.00053.00	GROMMET, SILICONE, LL & TEMP. PROBES
3	6	1024.00050.00	GROMMET, SILICONE, 11.4mm ID
4	1	1024.00051.00	GROMMET, SILICONE, BLANK
5	2	1107.00018.00	HEATER ASSEMBLY, IMMERSION 3000W/240VAC
6	1	1003.00005.00	BRACKET, ONE SHOT THERMOSTAT
7	1	1053.00003.00	THERMOSTAT, SINGLE SHOT, 240V/40A
8	2	1083.00009.00	WASHER, #6 SCREW , INTL TOOTH LOCKWASHER
9	2	1084.00010.00	NUT, HEX, #6-32, UNDERSIZED, ZINC PLATED
10	2	1003.00140.00	ALUMINUM BRACKET FOR SSR
11	2	1052.00016.00	ASSEMBLY RELAY, SOLID STATE, 50A/600VAC
12	4	1081.00042.00	STANDOFF, 6-32 x1.25 LG., 1/4 HEX WIDTH
13	1	1112.00002.00	PROBE WELDMENT, WATER LEVEL 2.25" LG
14	1	1102.00161.00	PROBE ASSEMBLY, TEMP. AND LLC, HWD-2100
15	1	1024.00007.00	O-RING, DASH #344, TANK COVER
16	1	1102.00007.00	TANK COVER ASSEMBLY
17	2	1023.00167.00	FITTING, BREW, GROMMET DESIGN
18	1	1023.00168.00	FITTING, HOT WATER, GROMMET DESIGN
19	1	1023.00166.00	FITTING, COLD WATER INLET, GROMMET DESIGN
20	1	1022.00057.00	TANK INSULATION, CBS-2132e, GROMMET DESIGN
21	6	1065.00006.00	CONNECTOR, TAB, .250", FASTON
22	1	1044.00004.00	LABEL, DANGER, HIGH VOLTAGE

1102.00183.00 PCSD Pump Spray Housing Assembly Parts

Ref.	QTY	PART NO	DESCRIPTION
1	1	1102.00020.00	SPRAY HOUSING ASSY& MAGNETS, CSD DESIGN
2	1	1024.00045.00	O-RING, 5/8 X 13/16, 3/32
3	1	1023.00164.00	SPRAY HOUSING ADAPTER
4	2	1082.00068.00	SCREW, M3.9x13, CHEESE PH., T/FORM
5	1	1102.00019.00	CASCADE SPRAY DOME ASSEMBLY

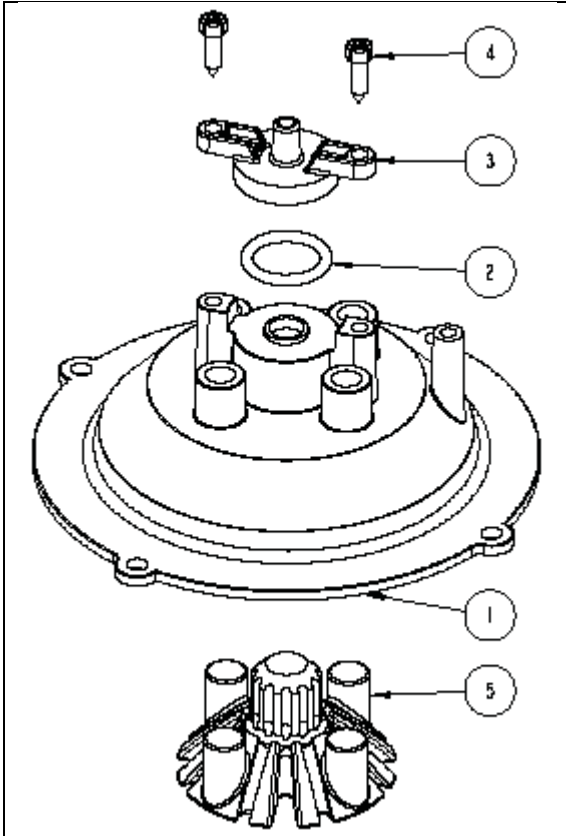

**Complete CBS-2130 Spray Housing Assembly
-Part number 1102.00183.00**

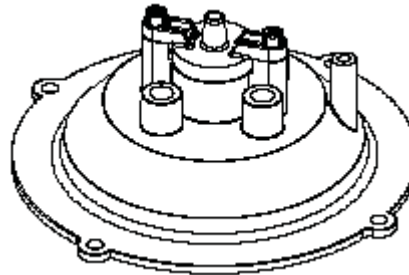

CBS-2100 Series Brew Basket Assembly, 13" X 5", Part # B012280B1 (SQUARE)

Ref#	Qty	Part Number	Description
1	1	1112.00073.00	BB WLDMNT, 13"X5", W/ Ø.280 HOLE
2	1	1102.00064.00	HANDLE W/MAGNET ASSEMBLY, BLACK RUBBER
3	1	1082.00040.00	SCREW, 1/4-20 X .5, FL HD, PH., W/NYLON
4	1	1009.00006.00	BASKET, WIRE, 13" X 5", CBS-2040'S
5	1	1046.00025.00	LABEL, BREW BASKET WARNING



Never strike or hit a brewbasket against any hard surface

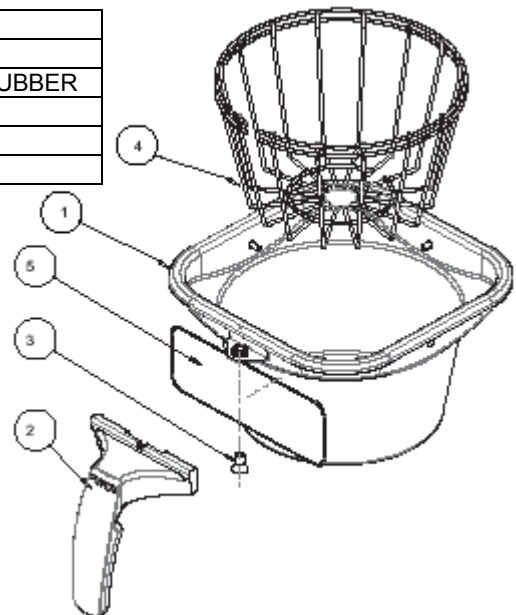

REVISIONS

REV	DATE	ECO NO	DESCRIPTION	BY:
A	06/07/12	N/A	ORIGINAL	LW
B	08/21/12	N/A	GND WIRE ADDED, REVISED	AG
C	10/22/12	N/A	REVISED WIRE CONNECTION	AG

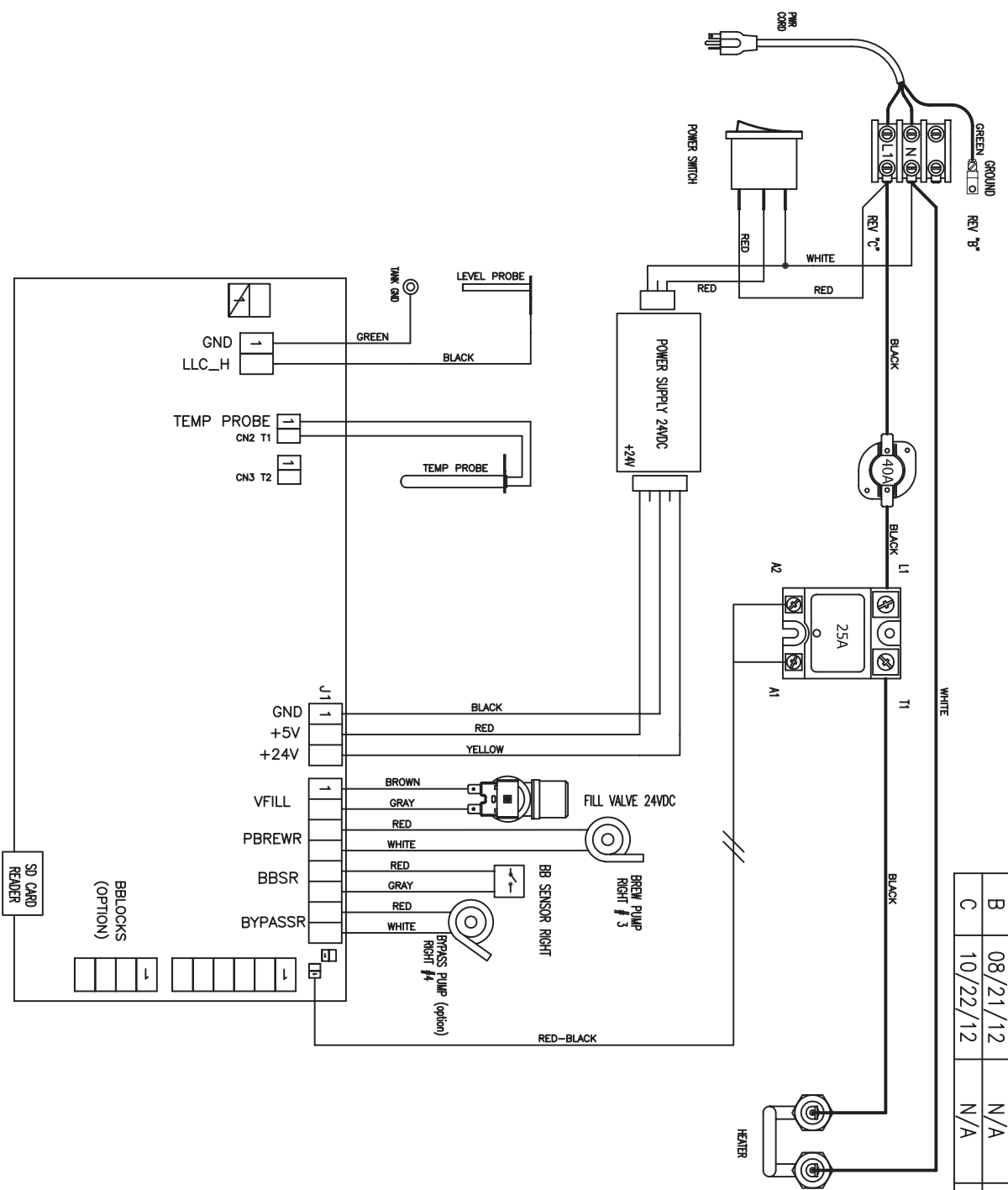

PROPRIETARY AND CONFIDENTIAL.
 THE INFORMATION CONTAINED IN THIS DRAWING IS THE SOLE PROPERTY OF FETCO. ANY REPRODUCTION IN PART OR AS A WHOLE WITHOUT THE WRITTEN PERMISSION OF FETCO IS PROHIBITED.

TOLERANCES		REVISIONS	
EXCEPT AS NOTED	NO.	DATE	BY
DECIMAL	A	06-07-12	LW
FRACTIONAL	B	08-21-12	AG
ANGULAR	C	10-22-12	AG
	D		
	E		

DWG. NAME: WIRING, CBS-2131, L1, N+GND, 1 HEATER
DRAWN BY: LW
SCALE: N/A
CHK'D: AS
DATE: 06-07-2012
APP'D:

DRAWING NO.: 1401.00042.00

FETCO
 FOOD EQUIPMENT TECHNOLOGICAL COMPANY
 600 ROSE RD.
 LAKE ZURICH, IL 60047
 WWW.FETCO.COM
 PHONE: 847-719-3001

REVISIONS

REV	DATE	ECO NO	DESCRIPTION	BY:
A	07/02/12	N/A	SECOND SSR ADDED	LW
B	10/22/12	N/A	REVISED WIRE CONNECTION	AG

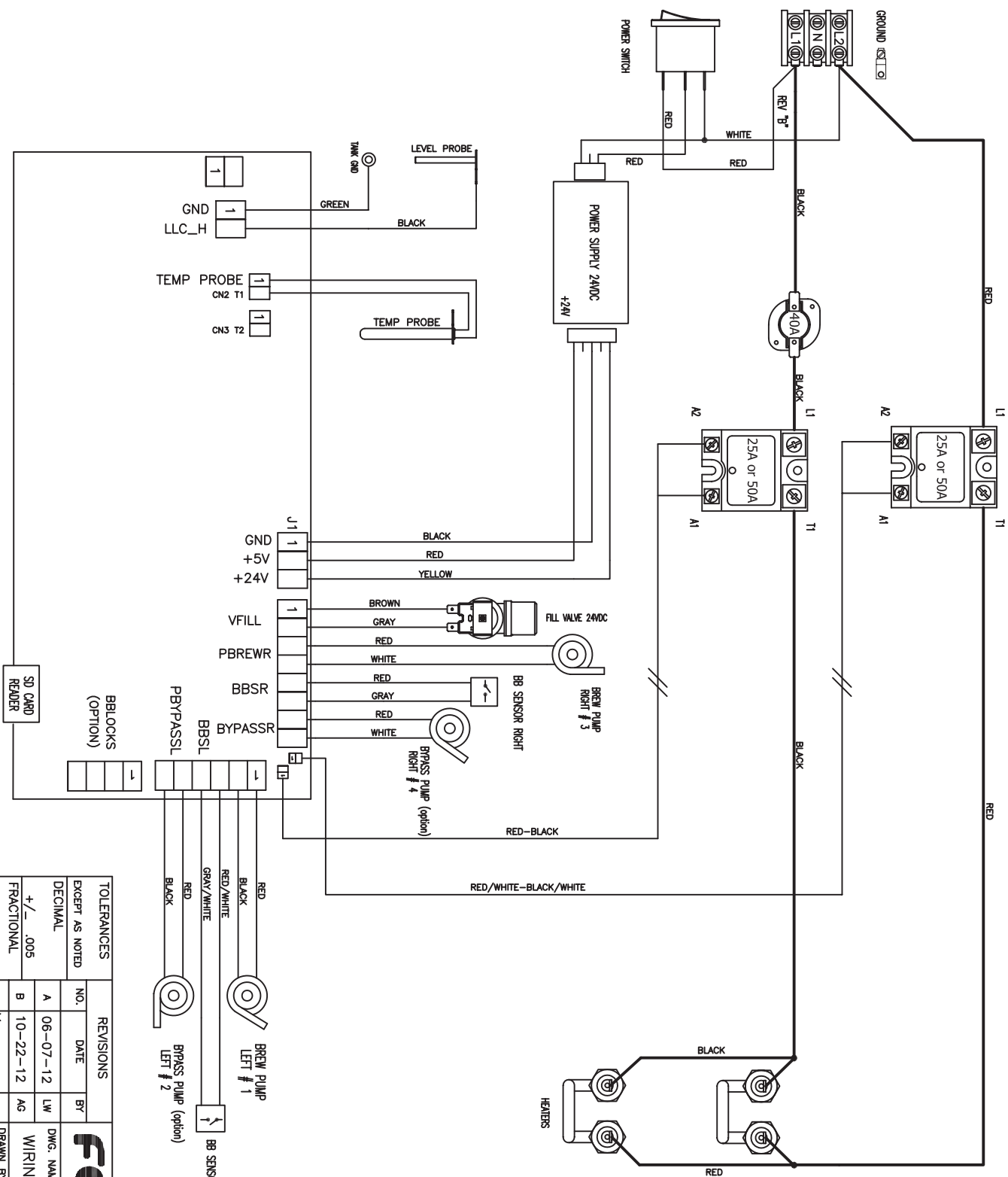

PROPRIETARY AND CONFIDENTIAL.
 THE INFORMATION CONTAINED IN THIS DRAWING IS THE SOLE PROPERTY OF FETCO.
 ANY REPRODUCTION IN PART OR AS A WHOLE WITHOUT THE WRITTEN PERMISSION OF FETCO IS PROHIBITED.

TOLERANCES		REVISIONS		DWG. NAME:		MATERIAL
EXCEPT AS NOTED	NO.	DATE	BY	WIRING,	SCALE	
DECIMAL	A	06-07-12	LW	CBS_2132, L1, L2, GND, 2 HEATERS	N/A	N/A
FRACTIONAL	B	10-22-12	AG			
+/- 1/64"	C					
+/- 1/32"	D					
+/- 1/2 DEG	E					

FETCO
 FOOD EQUIPMENT TECHNOLOGICAL COMPANY
 600 ROSE RD.
 LAKE ZURICH, IL 60047
 WWW.FETCO.COM

DRAWING NO. 1401.00043.00
 DATE 06-07-2012